

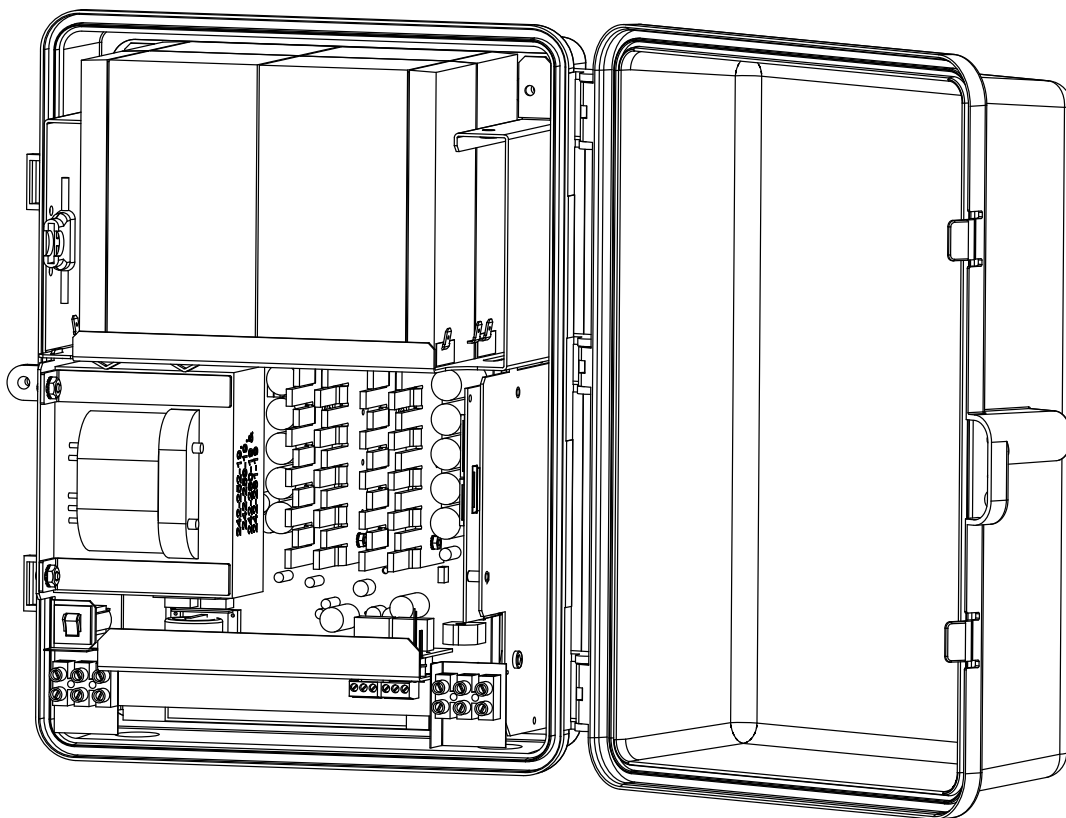

# Alpha Micro Secure UPS

## Installation and Operation Manual





# Alpha Micro Secure UPS Installation and Operation Manual

 **NOTE:**

---

**Photographs contained in this manual are for illustrative purposes only. These photographs may not match your installation.**

 **NOTE:**

---

**Operator is cautioned to review the drawings and illustrations contained in this manual before proceeding. If there are questions regarding the safe operation of this powering system, contact Alpha Technologies or your nearest Alpha representative.**

 **NOTE:**

---

**Alpha shall not be held liable for any damage or injury involving its enclosures, power supplies, generators, batteries, or other hardware if used or operated in any manner or subject to any condition inconsistent with its intended purpose, or if installed or operated in an unapproved manner, or improperly maintained.**

For technical support, contact Alpha Technologies:

Canada and USA: **1-888-462-7487**

International: **+1-604-436-5547**

Email: **support@alpha.ca**

## Copyright

Copyright © 2010 Alpha Technologies Ltd. All rights reserved. Alpha is a registered trademark of Alpha Technologies.

No part of this documentation shall be reproduced, stored in a retrieval system, translated, transcribed, or transmitted in any form or by any means manual, electric, electronic, electromechanical, chemical, optical, or otherwise without prior explicit written permission from Alpha Technologies.

This document, the software it describes, and the information and know-how they contain constitute the proprietary, confidential and valuable trade secret information of Alpha Technologies, and may not be used for any unauthorized purpose, or disclosed to others without the prior written permission of Alpha Technologies.

The material contained in this document is for information only and is subject to change without notice. While reasonable efforts have been made in the preparation of this document to assure its accuracy, Alpha Technologies assumes no liability resulting from errors or omissions in this document, or from the use of the information contained herein. Alpha Technologies reserves the right to make changes in the product design without reservation and without notification to its users.

# Table of Contents

1. Safety.....	4
1.1 Safety Symbols .....	4
1.2 General Warnings and Cautions .....	5
1.3 Certifications and Compliances.....	6
2. General Description .....	7
2.1 Overview .....	7
3. Site Planning.....	9
3.1 Safety Precautions .....	9
3.2 Electromagnetic Compatibility (EMC) Requirements .....	9
4. Unpacking Alpha Micro Secure.....	10
5. Installation.....	11
5.1 Transporting and Lifting.....	11
5.2 Mounting Options .....	11
5.3 Wiring the Alpha Micro Secure.....	15
5.4 Installing and Wiring the Batteries.....	16
5.5 Powering Up the Alpha Micro Secure .....	17
6. Operation .....	18
6.1 Communicating with the Alpha Micro Secure.....	19
6.2 Communicating with the RS-232 interface.....	20
6.3 Using the Main Menu .....	21
6.4 RS-232 Menu Tree.....	22
6.5 Operation .....	34
6.6 Communicating Via The Intranet or Internet .....	55
7. Maintenance .....	58
7.1 Updating the Software.....	58
7.2 Testing and Replacing the Batteries.....	61
7.3 Preventative Maintenance.....	64
8. Troubleshooting .....	65
9. Specifications.....	66

- 10. Peukert Number and Battery Capacity .....69
  - 10.1 Introduction ..... 69
  - 10.2 Determining the Peukert’s Number and Peukert’s Capacity ..... 69
  - 10.3 Determining Peukert’s Capacity for Series Parallel Combinations ..... 69
  - 10.4 Example ..... 70
  - 10.5 Using the Spreadsheet..... 71
- 11. Warranty .....72
  - 11.1 Battery Warranty..... 72
- 12. Emergency Shutdown Procedure .....73

# 1. Safety

---

**SAVE THESE INSTRUCTIONS:** This manual contains important safety instructions that must be followed during the installation, servicing, and maintenance of the product. Keep it in a safe place. Review the drawings and illustrations contained in this manual before proceeding. If there are any questions regarding the safe installation or operation of this product, contact Alpha Technologies or the nearest Alpha representative. Save this document for future reference.

## 1.1 Safety Symbols

To reduce the risk of injury or death, and to ensure the continued safe operation of this product, the following symbols have been placed throughout this manual. Where these symbols appear, use extra care and attention.

The use of ATTENTION indicates specific regulatory/code requirements that may affect the placement of equipment and /or installation procedures.



### **NOTE:**

**A NOTE provides additional information to help complete a specific task or procedure. Notes are designated with a checkmark, the word NOTE, and a rule beneath which the information appears.**



### **CAUTION!**

**CAUTION indicates safety information intended to PREVENT DAMAGE to material or equipment. Cautions are designated with a yellow warning triangle, the word CAUTION, and a rule beneath which the information appears.**



### **WARNING!**

**WARNING presents safety information to PREVENT INJURY OR DEATH to personnel. Warnings are indicated by a shock hazard icon, the word WARNING, and a rule beneath which the information appears.**



### **HOT!**

**The use of HOT presents safety information to PREVENT BURNS to the technician or user.**

## 1.2 General Warnings and Cautions

You must read and understand the following warnings before installing the Alpha Micro Secure and its components. Failure to do so could result in personal injury or death.

- Read and follow all instructions included in this manual.
- Do not work alone under hazardous conditions.
- Only qualified personnel are allowed to install, operate and service this system and its components.
- Use proper lifting techniques whenever handling equipment, parts, or batteries.
- Always assume electrical connections or conductors are live. Switch off all circuit breakers and double-check connections with a voltmeter before performing installation or maintenance.
- Place warning label(s) on the utility panel to tell emergency personnel a UPS is installed.
- The Alpha Micro Secure uses more than one live circuit. AC power may be present at the outputs even if the system is disconnected from line or battery power.
- The Alpha Micro Secure's surface can be very hot to the touch.
- Battery installation and servicing should be done or supervised by personnel knowledgeable about batteries and their safety procedures.
- If electrolyte splashes on your skin, immediately wash the affected area with water. If electrolyte gets into your eyes, wash them for at least 10 minutes with clean running water or a special neutralizing eye wash solution. Seek medical attention at once.
- Neutralize spilled electrolyte with special neutralizing solutions in a "spill kit" or a solution of 1 lb. (0.45 kg) of baking soda (bicarbonate of soda) in 1 gallon (3.8 L) of water.
- Be extra cautious when connecting or adjusting battery cabling. An improperly connected battery cable or an unconnected battery cable can result in arcing, fire, or explosion.
- Use new batteries when installing a new unit. Verify that all batteries are the same type with identical date codes.
- Always replace batteries with ones of identical number, type and rating. Never install old or untested batteries. One sealed lead-acid battery is rated to a maximum voltage of 12 VDC.
- A battery that shows signs of cracking, leaking or swelling must be replaced immediately by authorized personnel using a battery of identical type and rating.
- Keep the chassis area clear and dust-free during and after installation.
- Keep tools away from walk areas where you or others could fall over them.
- Wear safety glasses when working under any conditions that might be hazardous to your eyes.
- Do not work on the unit or connect or disconnect cables during periods of lightning activity.
- Do not smoke or introduce sparks in the vicinity of a battery.
- Never open or damage the batteries. Released electrolyte is harmful to the skin and eyes. It may be toxic and hazardous to the environment.
- A battery can present a risk of electrical shock and high short-circuit current. The following precautions should be observed when working on batteries:
  - a. Remove watches, rings, or other metal objects.
  - b. Use tools with insulated handles.
  - c. Wear rubber gloves and boots.
  - d. Do not lay tools or metal parts on top of batteries.
  - e. Disconnect the charging source before connecting or disconnecting battery terminals.
  - f. Determine if the battery is inadvertently grounded. If inadvertently grounded, remove the source from the ground. Contact with any part of a grounded battery can result in electrical shock. The likelihood of such shock can be reduced if the grounds are removed during installation and maintenance (applicable to equipment and remote battery supplies not having a grounded supply circuit).

- Never let live battery wires touch the Alpha Micro Secure the enclosure or any other metal objects. This can cause a fire or explosion.
- Never dispose of batteries in a fire. The batteries may explode. Follow the manufacturer's directions and check with your local jurisdictions for safe battery disposal.
- Before attaching the batteries to the Alpha Micro Secure make sure that the polarity is correct.
- If the batteries have been in storage for more than 3 months, recharge them for at least 24 hours and then test them with a load before installation.
- Each AlphaCell™ battery has a date code, found on the warning label, which must be recorded in the maintenance log. If non-Alpha batteries are used, see the manufacturer's documentation for date code type and placement.

### **1.3 Certifications and Compliances**

The Alpha Micro Secure has been designed, manufactured, and tested to the requirements of the following national and international safety standards:

- CAN/CSA-C22.2 No. 107.3-05 – Uninterruptible Power Systems; additional requirements (RD): CAN/CSA-C22.2 No. 60950-1-03 - Information Technology Equipment - Safety.
- UL 1778 (Edition 4) – Uninterruptible Power Systems; additional requirements (RD): UL 60950-1 (Edition 1) - Information Technology Equipment - Safety.
- FCC CFR47 Part 15 Class A – This equipment has been tested and found to comply with the limits for a Class A digital device pursuant to part 15 of the FCC Rules. These limits are designed to provide reasonable protection against harmful interference when the equipment is operated in a commercial environment. This equipment generates, uses, and can radiate radio frequency energy and, if not installed and used in accordance with the instruction manual, may cause harmful interference to radio communications. Operation of this equipment in a residential area is likely to cause harmful interference in which case the user will be required to correct the interference at his own expense.



# 2. General Description

## 2.1 Overview

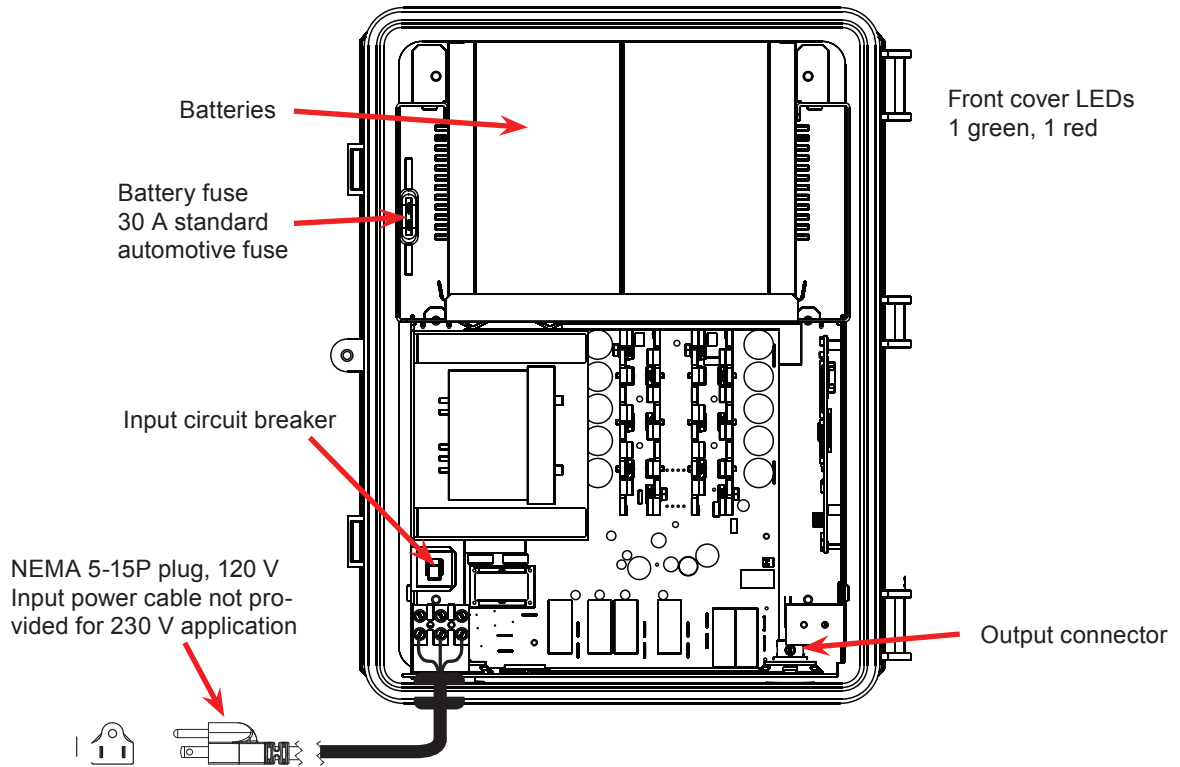

Figure 1 — Alpha Micro Secure Cable version

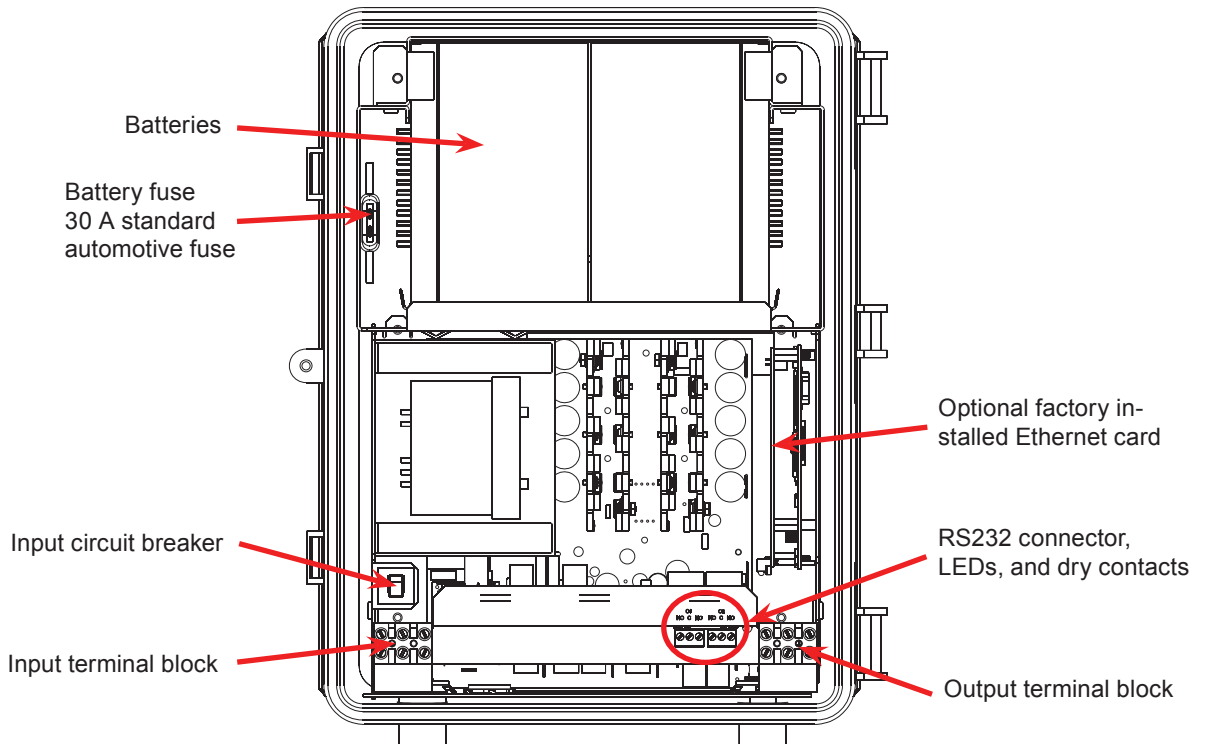

Figure 2 — Alpha Micro Secure Surveillance version

The surveillance version of the Alpha Micro Secure has a bar with monitoring LEDs, an RS-232 connector and dry contacts for attachment of an external monitoring panel.

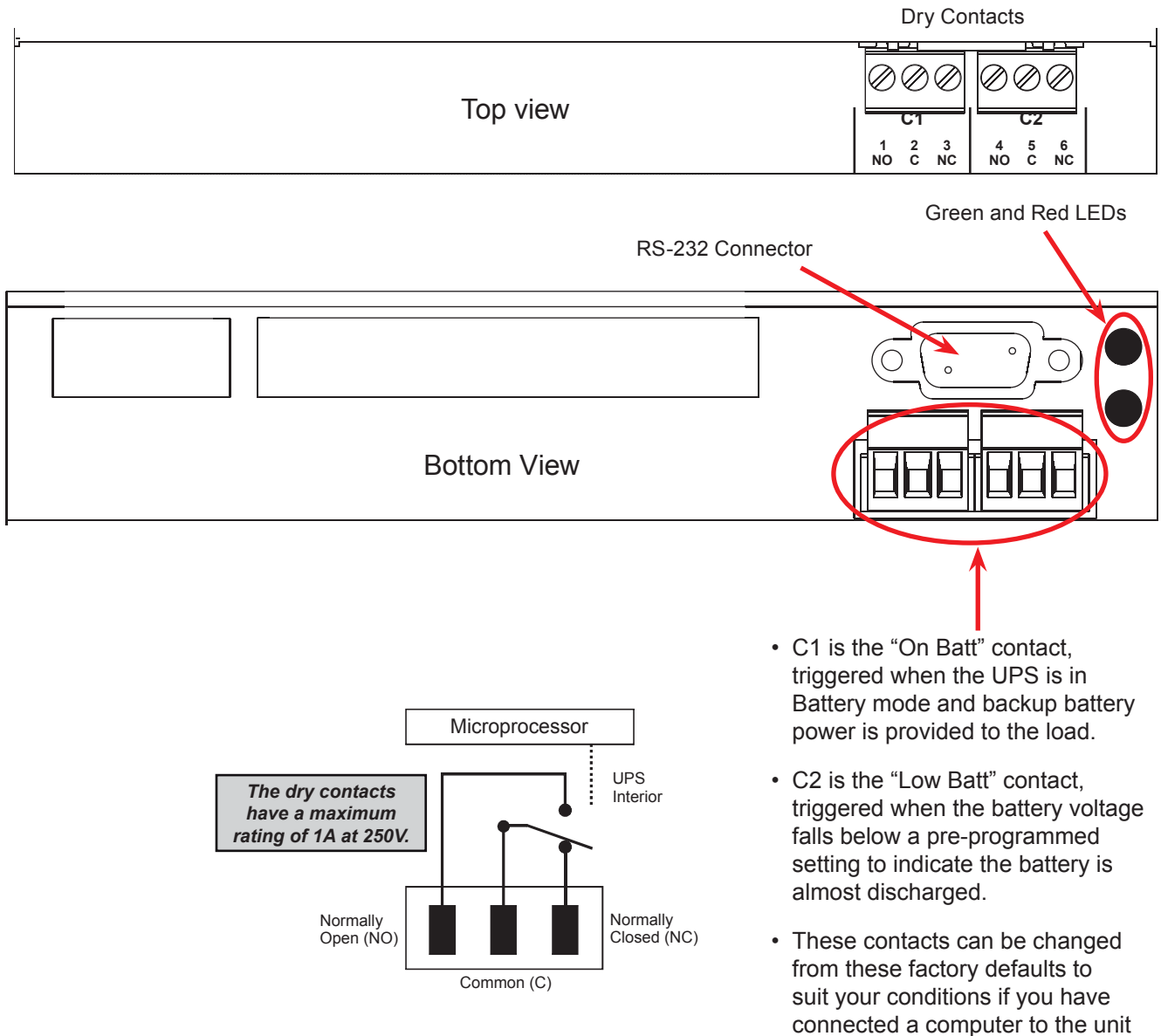

Figure 3 — Output Connectors and Monitoring LEDs

## 3. Site Planning

---



### WARNING!

The Alpha Micro Secure must be installed in a restricted area accessible only by qualified service personnel.

The Alpha Micro Secure must be correctly grounded for proper operation according to local and national electrical code.

The utility line attached to the Alpha Micro Secure input **MUST** be protected by a circuit breaker certified for this use in accordance with the local electrical code.

The AC input and AC output must each have a disconnect device attached. This device can be a listed branch circuit protection device or a disconnect switch used on AC Line only. Neutral or ground must never be disconnected by the user except during installation or maintenance.

### 3.1 Safety Precautions

- Install the Alpha Micro Secure and batteries in a restricted access location, and on a structure that supports the total weight.
- The input wiring must reach a suitably grounded power outlet and the load wiring must reach the Alpha Micro Secures output terminal blocks.

### 3.2 Electromagnetic Compatibility (EMC) Requirements

Observe the following EMC requirements when setting up the Alpha Micro Secure and its internal equipment:

- All AC mains and external supply conductors must be enclosed in a metal conduit or raceway when specified by local, national, and/or other applicable government codes and regulations.
- The customer facilities must provide suitable surge protection.

# 4. Unpacking Alpha Micro Secure

---

Follow these guidelines for unpacking the Alpha Micro Secure.



## WARNING!

**The Alpha Micro Secure is heavy, more than 45 kg (100 lb) with batteries. Use proper lifting techniques. The lifting and moving should be done by at least two people to avoid injury.**

1. Select a suitable area for unpacking.
2. Store all the packing material and boxes for possible equipment returns.
3. Check the contents in your product package. See “Checking the Package Contents” on this page.
4. Compare the packing slip and the list of parts with the items you received. If the list of parts on your packing slip does not match the items you received, or any items appear damaged, immediately notify your carrier agent and the supplier who prepared your shipment.

### 4.2.1 Checking the Package Contents

Before starting the installation, inspect the package contents and make sure the following standard items as well as purchased options are included.

<b>Quantity</b>	<b>Item</b>
1	Alpha Micro Secure UPS module.
1	Alpha Micro Secure Installation & Operation manual.
2	4 Phillips-head wood screws.
	2 or 4 batteries as ordered.
1	Battery fuse (Standard 30A automotive fuse).

# 5. Installation

---

Once the installation location has been planned and prepared, you are ready to install the Alpha Micro Secure. There are three steps to setting up the Alpha Micro Secure:

1. Mounting the Alpha Micro Secure.
2. Wiring the Alpha Micro Secure.
3. Installing and wiring the external batteries.

## 5.1 Transporting and Lifting



### WARNING!

**To avoid personal injury or damage to the equipment, always use at least two installation personnel to remove the unit from its container.**

**Batteries must not be installed until the Alpha Micro Secure enclosure has been securely set in place at its permanent location. Transporting the unit with batteries installed may cause a short circuit, fire, explosion, and/or damage to the battery pack, enclosure and installed equipment. Damage caused by improper shipping or transporting a unit with batteries installed is not covered by the warranty.**

## 5.2 Mounting Options

Choose any of the following four mounting options:

- Mounting to a wall.
- Mounting to a wooden pole.
- Mounting to a steel/concrete pole.

### 5.2.1 Mounting to a Wall

The Alpha Micro Secure can be mounted to a wall or to wall studs. The wall or studs should be able to hold a weight of at least 45.0 lbs (20.4 kg) and they must be plumb and the case mounted so it is level.

Using the case as a template, secure the case to the wall with the 4 Phillips-head wood screws supplied with the unit.

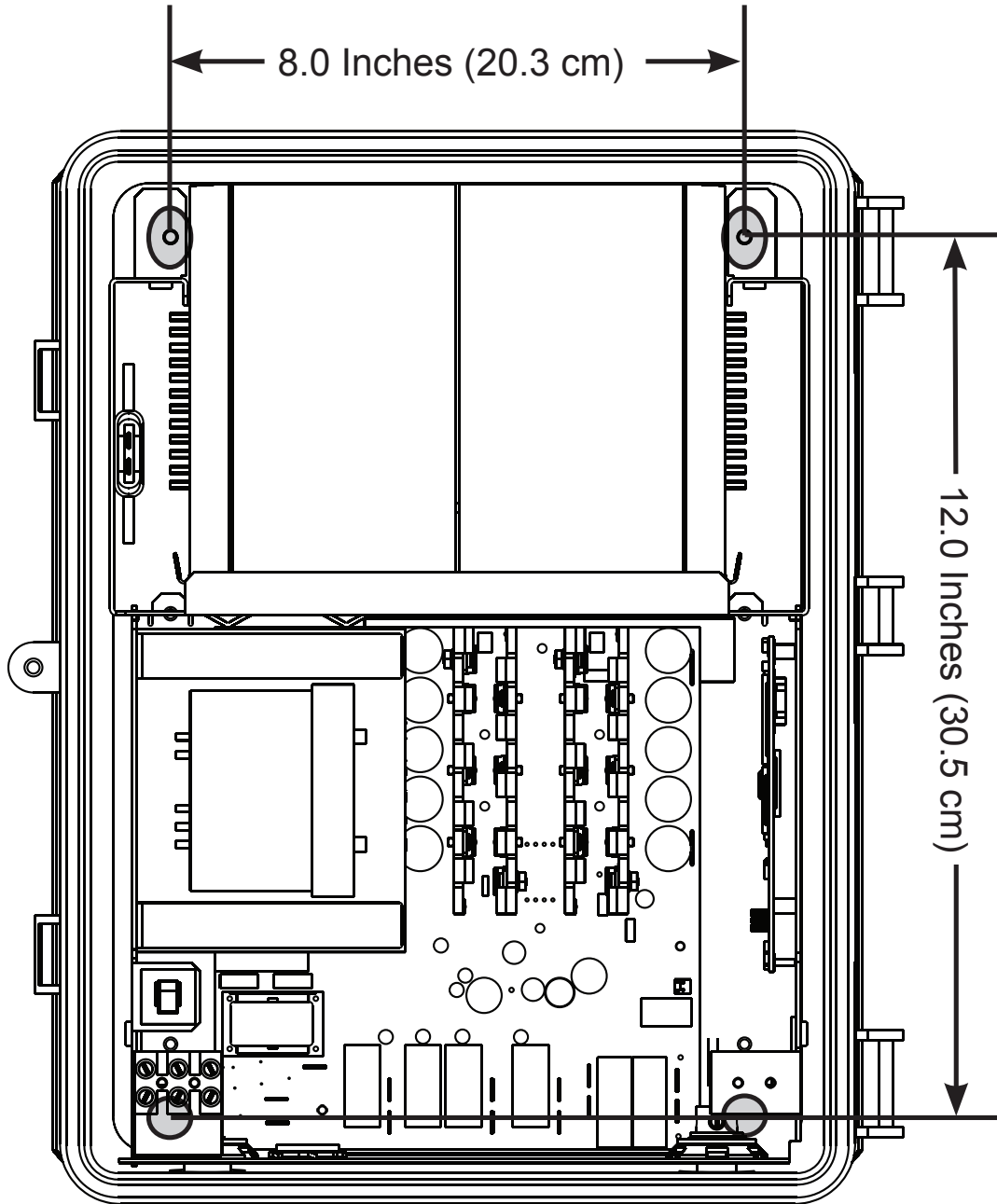

Figure 4 — Wall mounting template

## 5.2.2 Mounting to a Wooden Pole

The Alpha Micro Secure can be pole mounted with the optional mounting bracket (Alpha Kit# 740-751-21). It allows you to mount to either a vertical or horizontal, steel, concrete or wooden pole.

### Procedure

To bolt the UPS to the pole you need the optional mounting bracket and 2, ½" bolts (not provided) to fit the pole.

1. Drill holes into the pole to fit the bolts.
2. Attach the bracket to the pole.
3. Secure the UPS enclosure to the mounting bracket with the 2 mounting screws and 2 nuts provided with the kit.

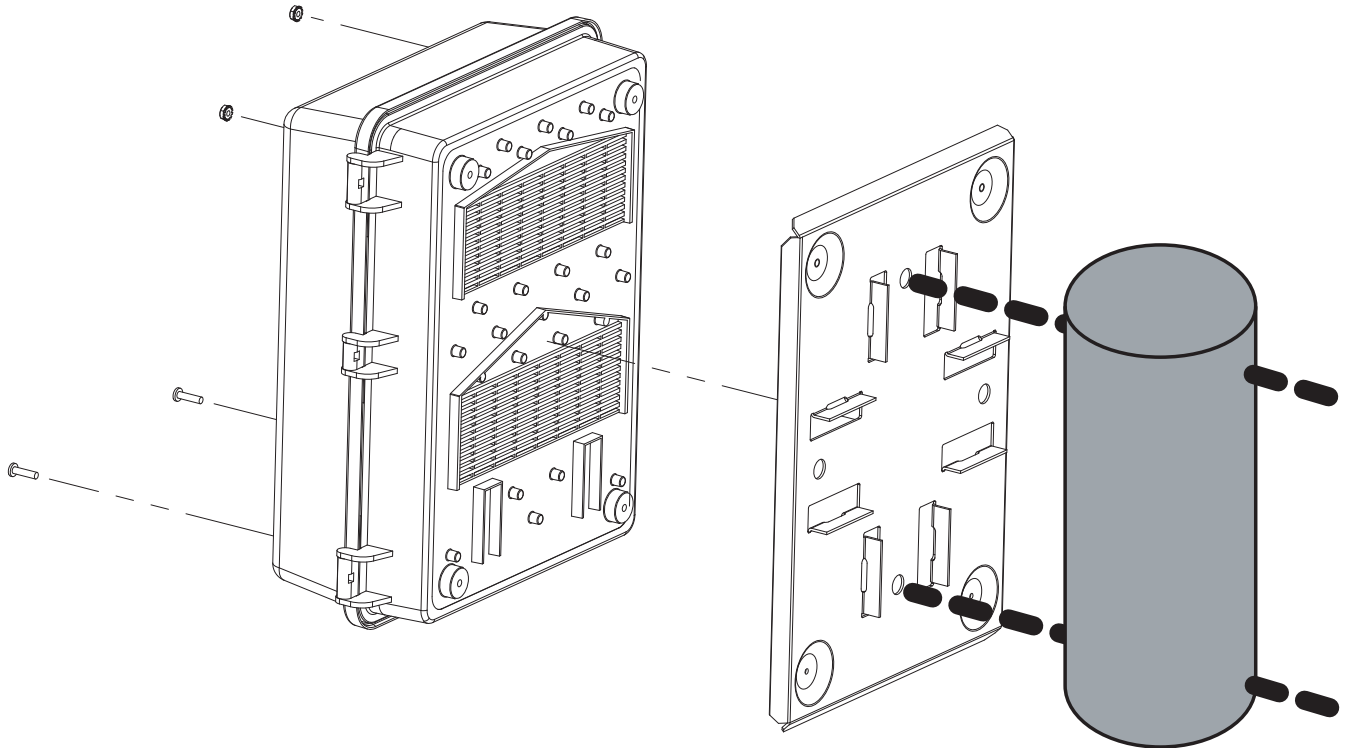

Figure 5 — Mounting to a wooden pole

### 5.2.3 Mounting to a steel or concrete pole

To strap mount the Alpha Micro Secure to the pole you need the optional mounting bracket and 2, 1/2" straps (Band-It #C20499 straps, #C00369 Tool and #C25499 Buckle or equivalent).

1. Attach the straps to the mounting bracket.
2. Attach the bracket to the pole.
3. Secure the UPS enclosure to the mounting bracket with the 2 mounting screws and 2 nuts provided with the kit.

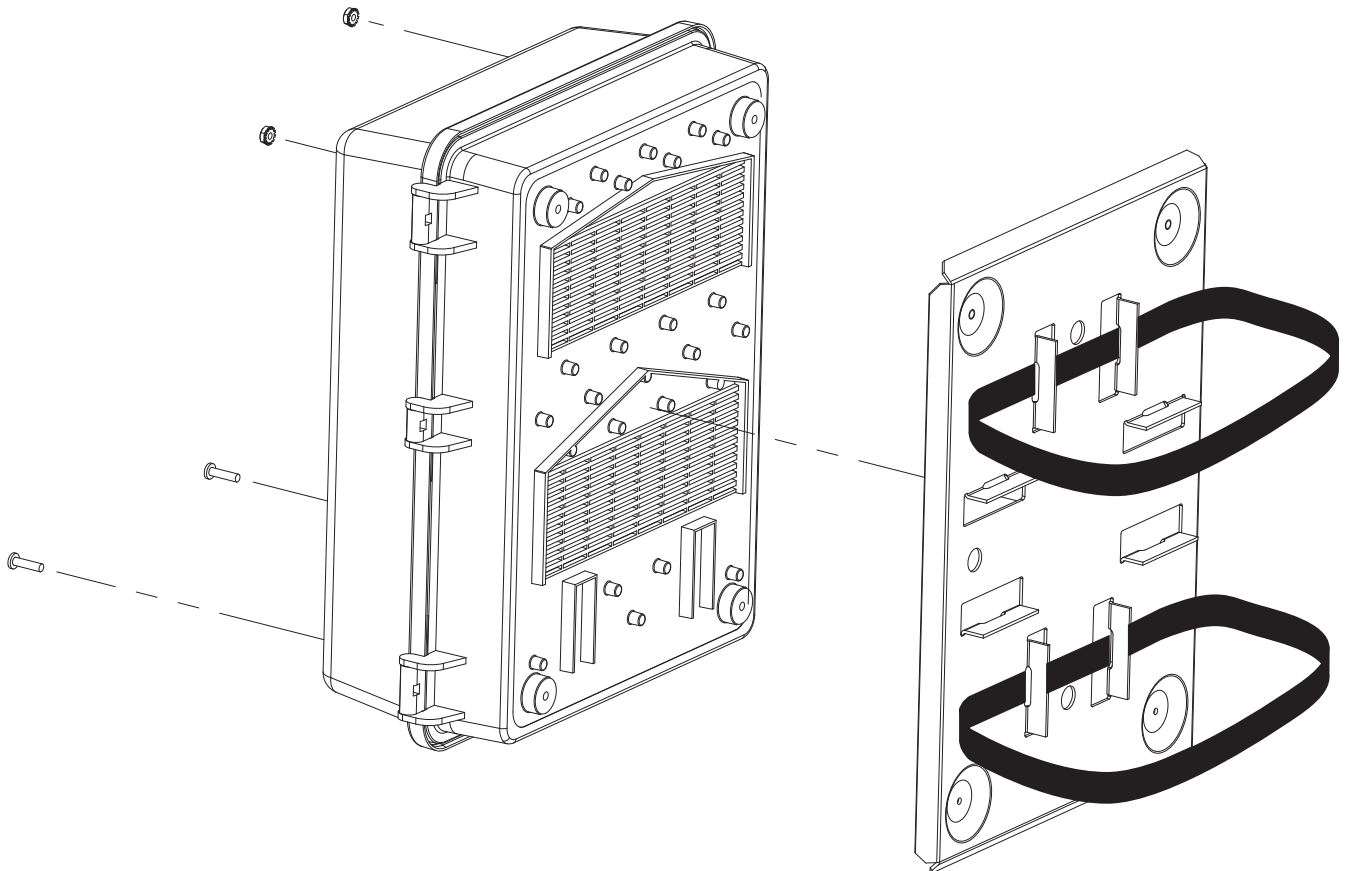

Figure 6 — Mounting to a steel or concrete pole



## 5.3 Wiring the Alpha Micro Secure



### WARNING!

The standard Alpha Micro Secure unit does not have an on/off switch. Whenever the UPS senses battery or line power, it is active and power is present at the output. Before starting, make sure line power is turned off and that the UPS's battery fuse is removed.

### 5.3.1 Tools and Materials Required

- Slotted-tip screwdrivers for tightening screws on terminal blocks.
- DC voltmeter.
- Maximum of 12 AWG wire for wiring the input and output terminal blocks.
- If used, maximum of 16 AWG wire for wiring the dry contact terminal blocks.

### Procedure

There are two different versions of the Alpha Micro Secure. For the surveillance version, you may have to connect the dry contact terminal block outputs and the RS-232 connector depending on your requirements.

1. Connect the load wiring to the output terminal block (surveillance version) as labeled. Torque to 7.0 lb-in (0.8 Nm). For the cable TV version, connect the load cable to the output cable connector.
2. On the surveillance version, if used, connect the dry contact terminal blocks and the RS-232 or Ethernet connectors. If using a conduit, drill a 1/2" hole to attach a matching conduit.
3. Wire the input terminal block according to its label. Torque to 7.0 lb-in (0.8 Nm).

The cable version has a 6-ft (2 m) permanently connected input power cable with a NEMA 5-15P plug for 120 V application. For 230 V application, connect the line power to the input terminal block through the provided 1/2" knockout hole.

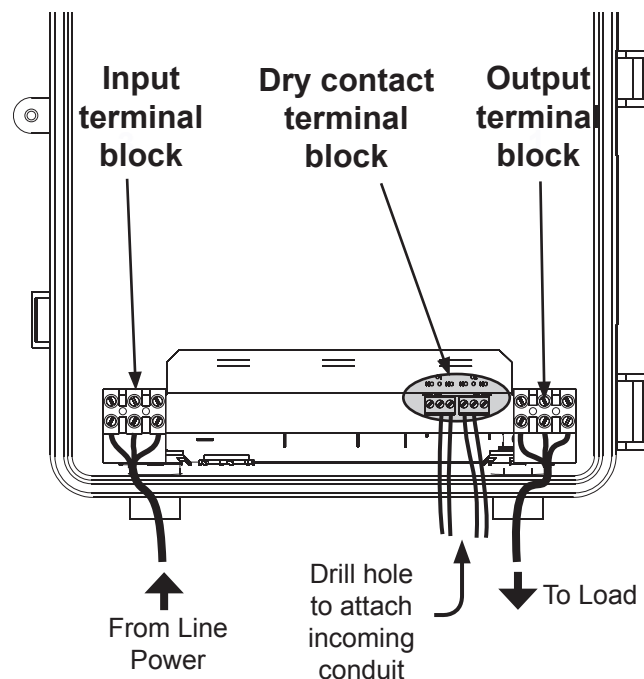

Figure 7 — Wiring the Alpha Micro Secure

## 5.4 Installing and Wiring the Batteries

### WARNING!

Before proceeding, verify the line wire is attached to the line terminal block, the ground wire is attached to the ground terminal block and the neutral wire is attached to the neutral terminal block to prevent accidental shocks or electrocutions.

Make sure the battery fuse is removed before wiring the batteries.

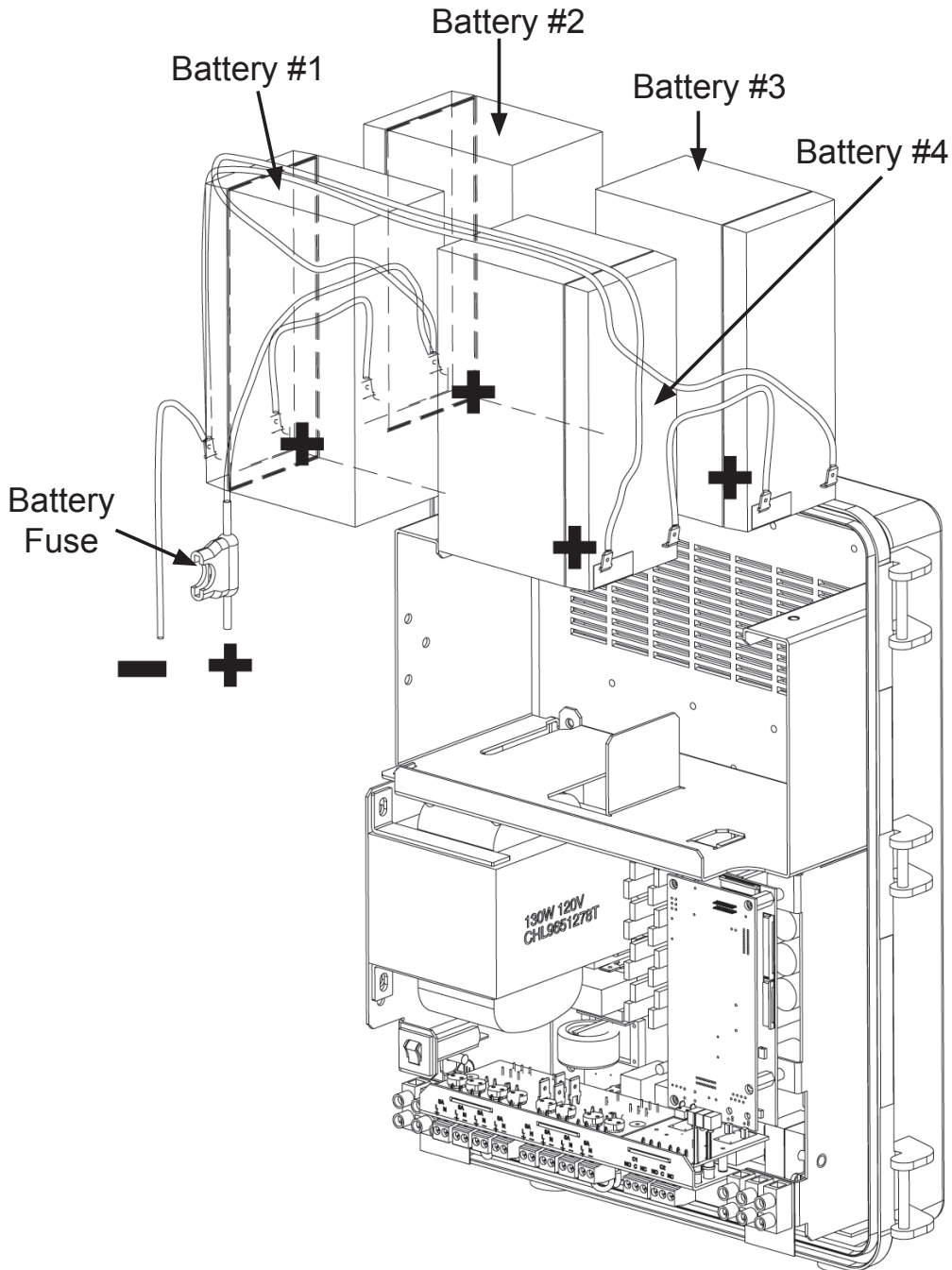

Figure 8 — Battery Locations

## Procedure

1. Install the 4 batteries and wire them up as shown in Figure 8 and Figure 9.

If using only 2 batteries, install them in the Battery #1 and Battery #2 positions and wire them up as shown in Figure 6.2, except the wires to Battery #3 and #4 are not used.

2. Use a DC voltmeter to verify the battery string's polarity and voltage (24 VDC). Perform troubleshooting if necessary.

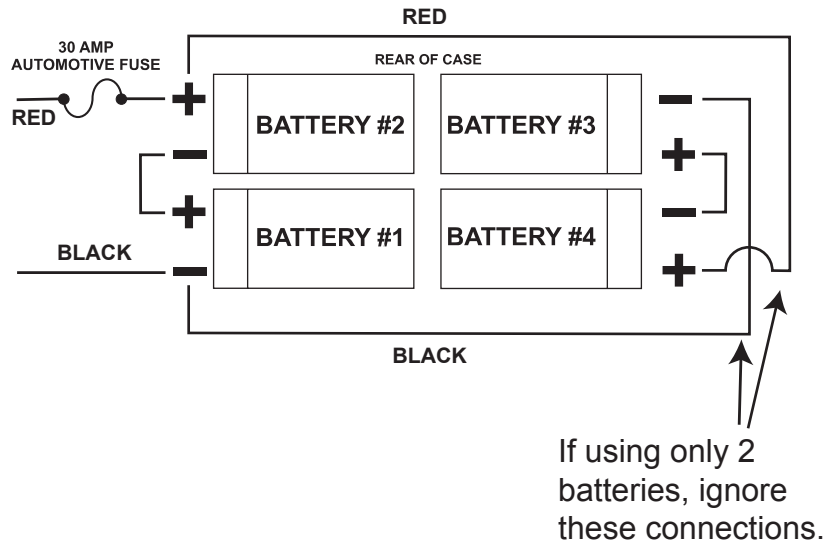

Figure 9 — Battery wiring diagram

## 5.5 Powering Up the Alpha Micro Secure

Make sure that the Line power is qualified but turned off and the batteries are fully charged.

### Procedure

1. Install the battery fuse by snapping it quickly into its fuse holder. Make sure it is firmly secured in the mount. You may hear a buzzing sound or see sparks when installing the fuse. This is normal and will not damage the UPS.
2. Switch on the Line power.
3. Ensure the LEDs are working. See LED status table below.
4. When Line power is first applied, both LEDs illuminate and then only the green light remains on if the UPS is in Line mode.

Table B — LED status description	
LED Status	Description
GREEN OFF	The UPS's inverter is turned off. Line power goes straight to the load.
GREEN ON	The UPS is turned on. Line power is provided to the load.
GREEN FLASHING	The UPS's inverter is on. Backup battery power is provided to the load.
RED ON OR FLASHING	The UPS has a malfunction. See the troubleshooting table below.

## 6. Operation

---

The following subsections describe the operation of the Alpha Micro Secure:

- Communicating with the Alpha Micro Secure.
- Communicating with the RS-232 interface.
- Adjusting and controlling the Alpha Micro Secure
- Viewing the 100-event log.
- Communicating with the Alpha UPS Monitor.

## 6.1 Communicating with the Alpha Micro Secure

There are several ways you can communicate with the Alpha Micro Secure UPS:

1. Using a RS-232 interface, you can access the UPS's command line system with Window's HyperTerminal or other terminal emulation program.
2. Using a RS-232 serial connection via the Alpha UPS Monitor installed on your computer. The Alpha UPS Monitor software can be downloaded from [www.alpha.ca./downloads/](http://www.alpha.ca./downloads/).
3. Using the optional factory-installed communication module, you can communicate with the Alpha Micro Secure over a company intranet or the internet using a web browser or with SNMP communications.

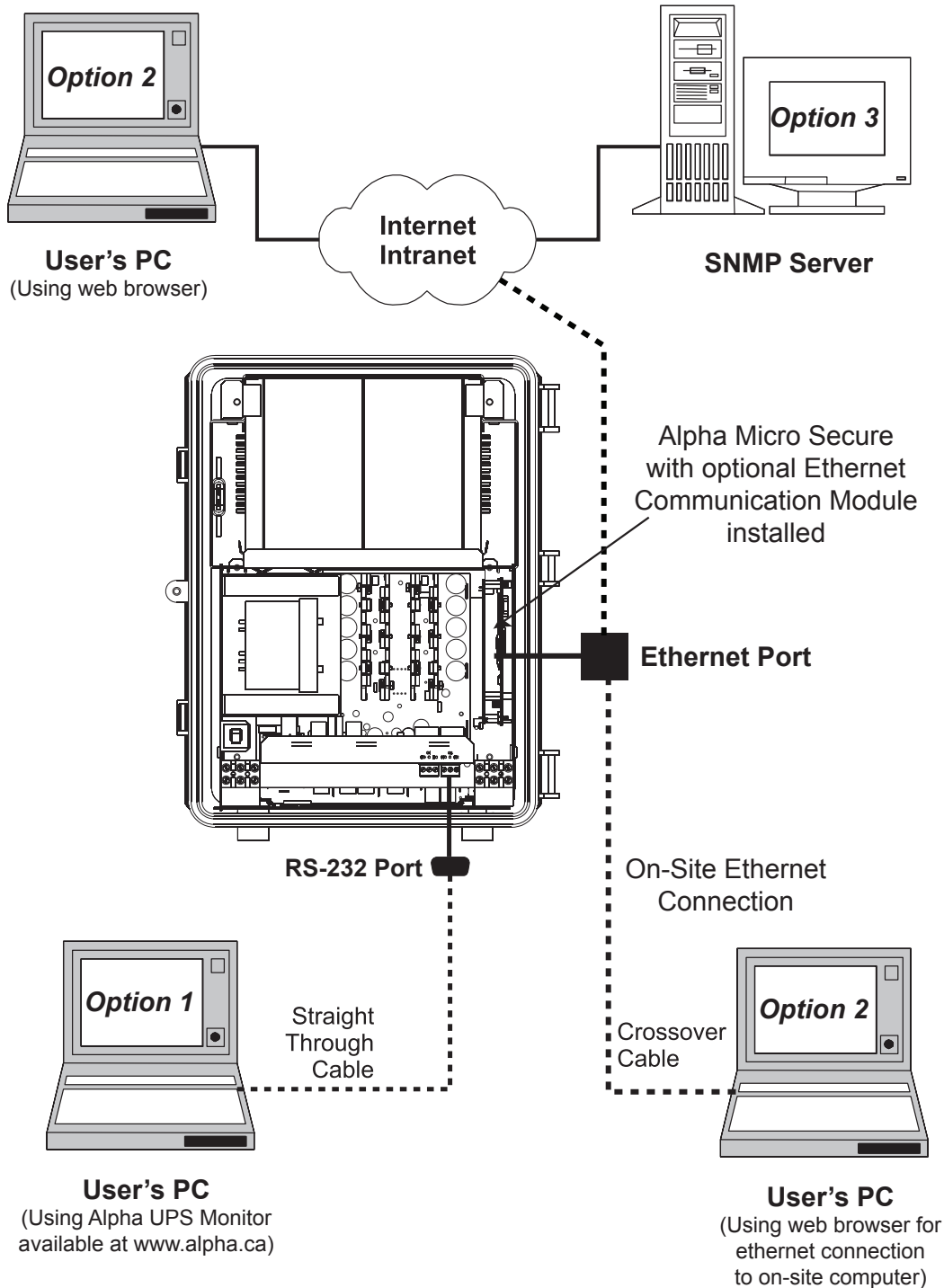

Figure 10 — Alpha Micro Secure Communication Options

## 6.2 Communicating with the RS-232 interface

### 6.2.1 Wiring the RS-232 port

The Alpha Micro Secure's front panel has a DE-9 female connector. When connected to a PC with Windows HyperTerminal or other terminal emulation software, the Alpha Micro Secure can be remotely monitored and controlled with its command-line system. The Alpha UPS Monitor provides a Windows or web browser type of control.

#### Procedure

1. Connect a 9-pin, fully shielded, straight-through DE-9 to DE-9 connector cable between the computer's port and the Alpha Micro Secure's port.

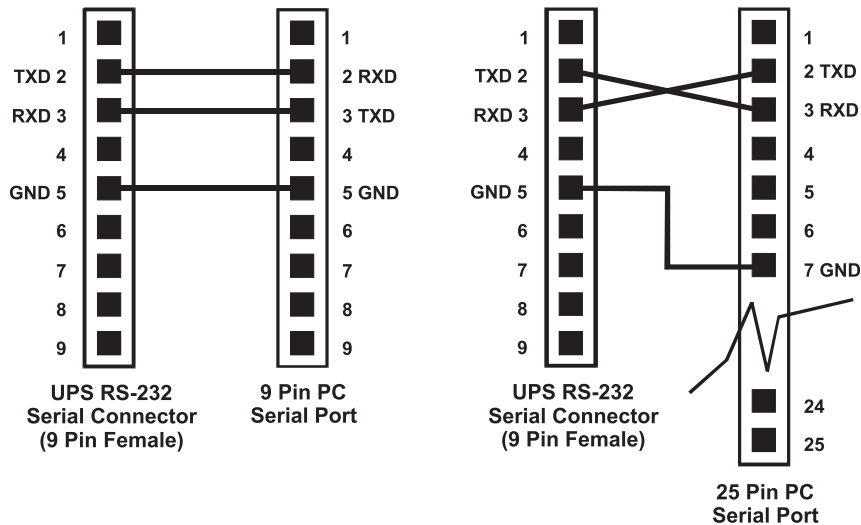

Figure 11 — RS-232 pin connections

2. Configure the communications parameters to the values shown in the terminal set up table below.

Table C — Terminal Set Up Table			
Emulation Type	VT 100 or Compatible	Backspace	N/A
Duplex Mode	Half Duplex	Break Length	N/A
Xon/Xoff Flow Control	None	Emulation Type	N/A
RTS/CTS Flow Control	Off	<b>Communication Parameters</b>	
Line Wrap	On	Handshaking	Software Handshaking
Screen Scroll	On	Baud Rate	2400 bps
CR Translation	CR	Data Format	8-bit Data, No Parity, 1 Stop Bit, No Flow Control.

## 6.3 Using the Main Menu

The Alpha Micro Secure's main menu screen runs on a command line system. This program does not recognize the backspace or delete keys even if it appears that way on the monitor. If you make a mistake and press **Enter**, the Alpha Micro Secure echoes the command back exactly as you typed it. Press **Enter** and retype the command again.

If you choose not to use the command line system, you can use the Alpha UPS Monitor to control and monitor the Alpha Micro Secure

### 6.3.1 Main Menu Screen

The main menu screen shows the Alpha Micro Secure's current input and output values, displays if any faults or alarms are present and gives access to the submenus. It can be accessed from anywhere in the menu tree by typing **0** and pressing **Enter**. The Alpha Micro Secure is controlled by submenu 3.

To access a particular submenu, type in the submenu number and press **Enter**. To update the main menu screen, press **Enter**.

The complete menu tree is given in Figure 14. Tables describing the Line Status, Output Status, Faults and Alarms displays are given in Tables G, H, I, and J.

- The readings on the main menu screen do not automatically update to reflect changes in the Alpha Micro Secure's status. Press **Enter** to update the screen.
- For many functions you need to enter a password. The factory setting is 1111.

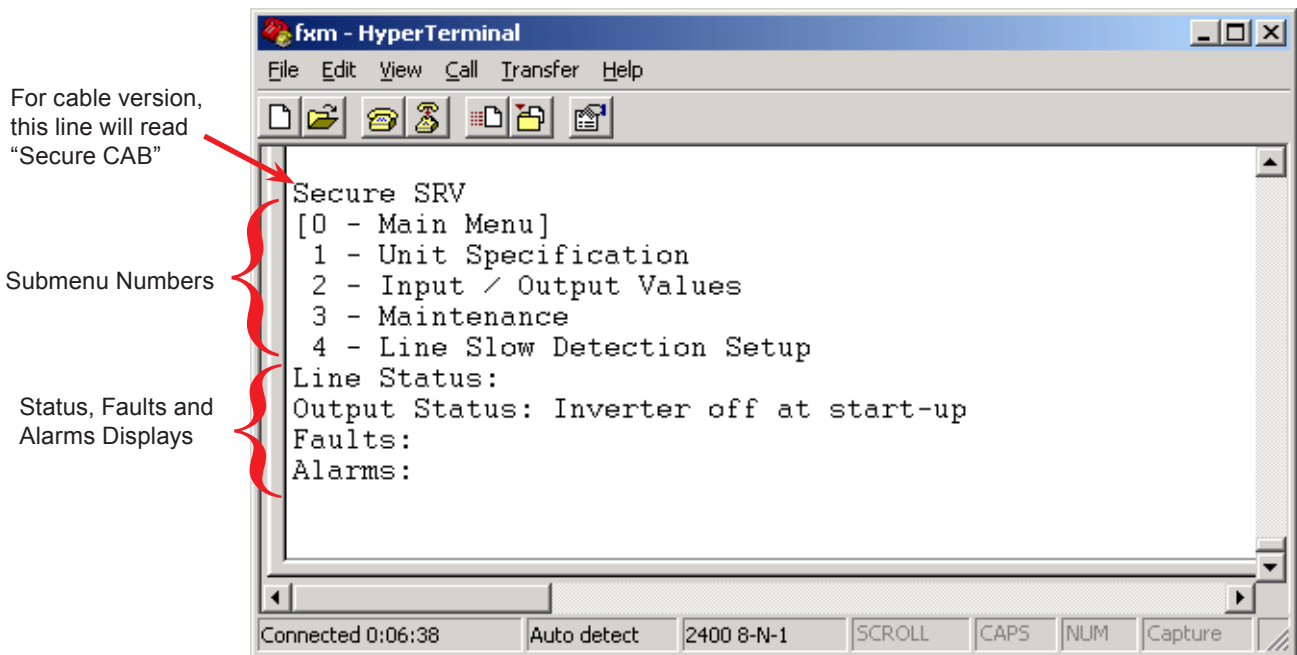

Figure 12 — Main Menu Screen

## 6.4 RS-232 Menu Tree

Submenus #1, 2 and 4 are read-only screens for monitoring the Alpha Micro Secure To control the Alpha Micro Secure use submenu #3, the Maintenance submenu.

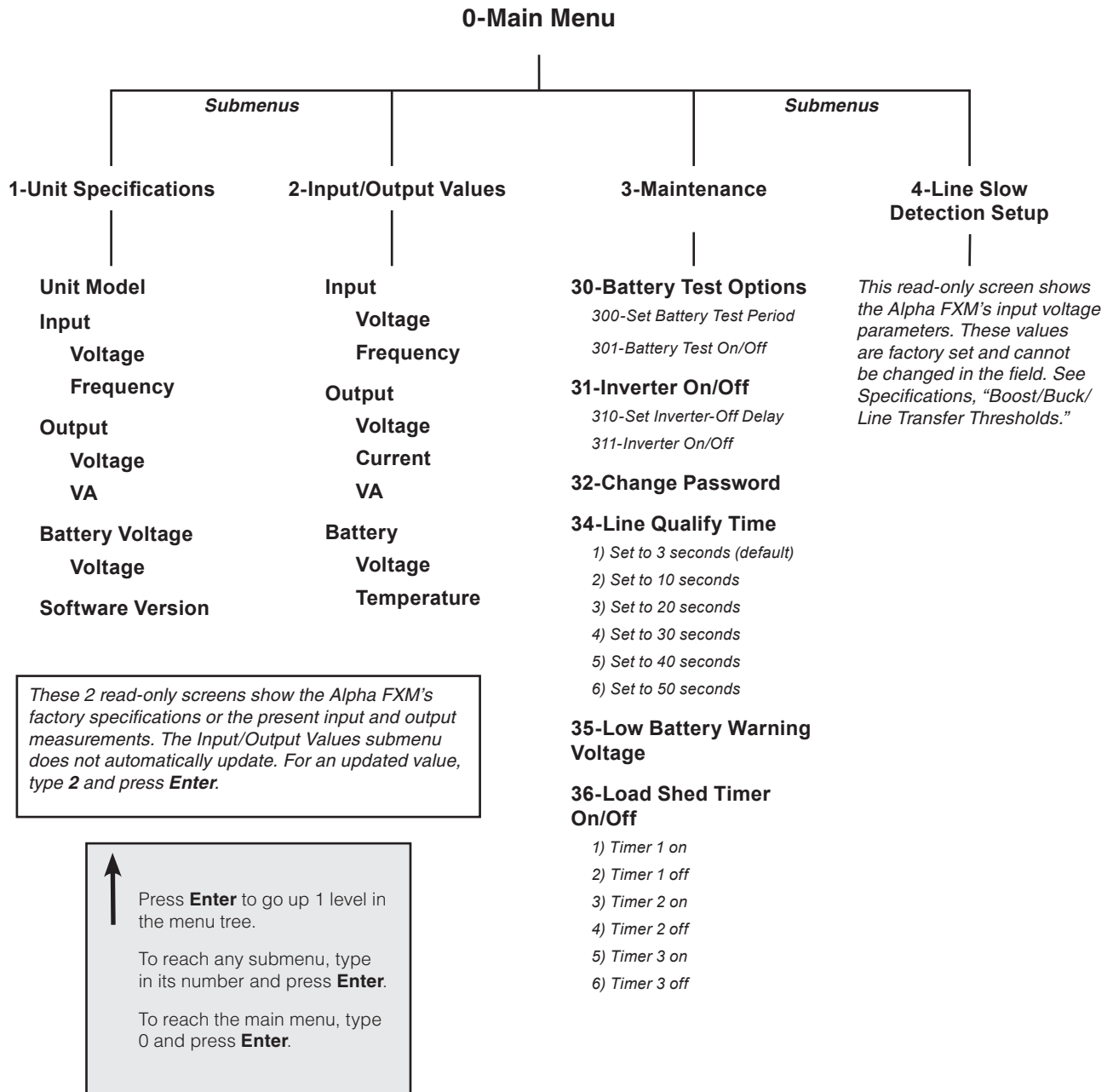

Figure 13 — RS-232 Menu Tree



## 6.4.1 Line Status

Line status tells you the line's condition. For an updated value, press **Enter**.

<b>Table D — Line Status</b>	
<b>Normal</b>	The line is within specifications. See specifications, "Boost/Buck/Line Transfer Thresholds". The Alpha Micro Secure is operating in Line mode.
<b>Boost</b>	Line voltage is out of tolerance. The Alpha Micro Secure is operating in Boost mode.
<b>Boost2</b>	Line voltage is out of tolerance. The Alpha Micro Secure is operating in Boost 2 mode.
<b>Buck</b>	Line voltage is out of tolerance. The Alpha Micro Secure is operating in Buck mode.
<b>Buck2</b>	Line voltage is out of tolerance. The Alpha Micro Secure is operating in Buck 2 mode.
<b>Blackout</b>	The line is absent.
<b>Freq low</b>	Line frequency is too low.
<b>Freq high</b>	Line frequency is too high.

## 6.4.2 Output Status

Output status tells you how the Alpha Micro Secure is producing power. For an updated value, press **Enter**.

<b>Table E — Output Status</b>
<b>Line mode</b>
<b>Battery mode</b>
<b>Battery mode, low bat. warning</b>
<b>Battery mode (testing battery)</b>
<b>Boost mode</b>
<b>Boost 2 mode</b>
<b>Buck mode</b>
<b>Buck 2 mode</b>
<b>Hot swap mode</b>
<b>Inverter off due to fault</b>
<b>Inverter off due to low battery</b>
<b>Inverter off at start-up</b>
<b>Shutdown due to user request</b>

### 6.4.3 Fault and Alarm Displays

Fault and alarm displays any malfunctions the Alpha Micro Secure has encountered. Also see "Troubleshooting".

<b>Table F — Faults</b>	
<b>Short_Circuit</b>	The load has a short.
<b>Vout_Hi</b>	The output voltage is above specifications.
<b>Batt_Hi</b>	The batteries cannot be charged.
<b>Batt_Lo</b>	The batteries are almost discharged.
<b>Vout_Lo</b>	The output voltage is below specifications.
<b>Overload</b>	The Alpha Micro Secure is overloaded. Remove excess loads.
<b>Backfeed</b>	A relay inside the Alpha Micro Secure has failed and it cannot be replaced in the field. Contact Alpha Technologies customer service department.
<b>Bad_Battery</b>	The battery voltage has dropped below a specified level. Inverter shuts down.
<b>Temp_Hi</b>	The Alpha Micro Secure is operating above temperature range.

<b>Table G — Alarms</b>	
<b>Overload</b>	The Alpha Micro Secure is overloaded. Switch off excess loads.
<b>Temp_Hi</b>	The ambient battery temperature is too high.
<b>Temp_Lo</b>	The ambient battery temperature is too low.
<b>User_Input</b>	The user input contact "User Input: S2" is shorted.
<b>Line_Freq</b>	The line frequency is outside of the Alpha Micro Secure's input specifications.
<b>No_Temp_Probe</b>	The battery temperature sensor has become disconnected or has failed.
<b>Weak_Battery</b>	The battery has failed the background scan in Line mode.
<b>Batt_Low</b>	The battery voltage is low.
<b>Batt_Brkr_Open</b>	The battery breaker is opened.
<b>Self_test</b>	The Alpha Micro Secure is performing self test.
<b>Fan_Fail</b>	The Alpha Micro Secure internal fan has failed.
<b>Wrong_Software</b>	The Alpha UPS Monitor is invalid (either version or part number).

## 6.4.4 Adjusting and Controlling the Alpha Micro Secure

The Maintenance submenu lets you control the Alpha Micro Secure and change selected items to meet your operational needs.

### Procedure

From the Main menu, type **3** and press **Enter**.

<b>Table H — Maintenance Submenu</b>	
<b>30 Battery Test Options</b>	This starts the battery test and sets how long the test will run. The default setting for the test duration is 2 minutes, but this can be adjusted in 1 minute intervals. See "Operating the Alpha Micro Secure, BATT TEST".
<b>31 Inverter On/Off</b>	This switches the inverter on or off to allow you to prevent a damaging deep battery discharge or to provide backup battery power to the load. See "Operating the Alpha Micro Secure INVERTER". You can set a delay before the inverter switches off to allow time for switching off critical loads. The Set Inverter ON/OFF delay is only available when the Alpha Micro Secure is in the Battery or Standby modes. The delay can be adjusted in 1 second steps with a default setting of 0 seconds to a maximum of 600 seconds (10 minutes). The delay is only available in the Standby or Battery modes. Once the Alpha Micro Secure returns to the Line mode, the delay resets itself to 0 seconds.
<b>32 Change Password</b>	This changes the Alpha Micro Secure's password. The factory set password is 1111, which can only be changed when the Alpha Micro Secure is in Line mode. The password is limited to 4 alpha-numeric characters in length.
<b>34 Line Qualify Time</b>	This lets you set the delay when the Alpha Micro Secure goes from Battery mode to Line mode after the line becomes requalified. The purpose of this delay is to make sure the line is stable before the Alpha Micro Secure switches back to it. See "Operating the Alpha Micro Secure, QUAL TIME". The default setting is 3 seconds, but you can set this to 3, 10, 20, 30, 40 or 50 seconds.
<b>35 Low Battery Warning Voltage</b>	The lets you set the Alpha Micro Secure's low battery warning voltage, adjusting the setting to match the batteries you are using and the actual operating conditions. The default value is 40% (47 VDC) and can be adjusted in 1% (0.05 VDC) increments between 45.0 (0 %) and 50.0 VDC (100%) by typing in the % battery voltage level where you want the warning to be triggered.
<b>36 Load Shed Timer On/Off</b>	This lets you switch the timer contacts on or off. See "Contacts C1 to C6".

## 6.4.5 Programming the Dry Contacts and the Clock

On the surveillance version of the Alpha Micro Secure, the front panel contacts (C1 to C6) can be programmed to meet your specifications with RS-232 communications. You can also adjust the Alpha Micro Secure's date and time.

### Programming the Dry Contacts

The functions of dry contacts C1 to C5 (and if factory configured, dry contact C6) can be changed with RS-232 communications.

For example, to change contact C1:

1. To see how it is currently programmed, type **c1** (all lower case) and press **Enter**.
2. The Alpha Micro Secure responds with **\*c1=1** where the **\*** shows the unit responded to your command. For example: a **"1"** shows it is programmed to be the **On Battery** indicator as shown in the Dry Contact Configuration table below.

Table I — Dry Contact Configuration		
<b>1= On Battery</b>	<b>4= Alarm</b>	<b>7= Timer 2</b>
<b>2= Low Battery</b>	<b>5= Fault</b>	<b>8= Timer 3</b>
<b>3= Timer 1</b>	<b>6= Disabled</b>	

3. To change the contact, type **c1=X** where X is 1 to 8 and press **Enter**. The Alpha Micro Secure responds with **\*c1=(1 to 8)**. The programming is done for that contact. Repeat as necessary for the other contacts.

Each contact can only be programmed for one function at a time and cannot show multiple conditions.

4. To reset the contacts to the factory default, type **default** and press **Enter**. The Alpha Micro Secure responds with **\*default**, showing it is reset. This command also resets the timer setting to the 2 hours factory default. See "Setting the Timer Contact". See "Specifications" for the factory default settings of dry contacts C1 to C6.

## 6.4.6 Setting the Timer Contact

The front panel's timer contact can be programmed to suit your application. See "Contacts C1 to C6" and "Programming the Dry Contacts and the Clock". The table below explains how.

	<b>Enter command</b>	<b>UPS display</b>	<b>Description</b>
Displaying the timer	<b>timer</b> and press <b>Enter</b>	*timer=02:00:00	Returns the value of timer
	<b>timer1</b> and press <b>Enter</b>	*timer1=02:00:00	Returns the value of timer1
	<b>timer2</b> and press <b>Enter</b>	*timer2=02:00:00	Returns the value of timer2
Setting the timer	<b>timer=00:01:00</b> and press <b>Enter</b>	*timer=00:01:00	Sets the value of timer1 to 60 seconds.
	<b>timer=00:01:00</b> and press <b>Enter</b>	*timer=120	
	<b>timer1=00:01:00</b> and press <b>Enter</b>	*timer1=00:01:00	Sets the value of timer1 to 60 seconds.
	<b>timer1=120<sup>†</sup></b> and press <b>Enter</b>	*timer1=120	
	<b>timer2=00:01:00</b> and press <b>Enter</b>	*timer2=00:01:00	Sets the value of timer2 to 60 seconds.
	<b>timer2=120<sup>†</sup></b> and press <b>Enter</b>	*timer2=120	
	<b>default</b> and press <b>Enter</b>	*default	Resets the timer to the factory default of 02:00:00 (2 hours); and resets contacts C1 to C5 to the factory default settings. See "Programming the Dry Contacts".

Note: In the above example, the default timer setting of 2 hours is used.

\* Indicates that the Alpha Micro Secure has responded to the command you entered.

† Time can be entered in units of 0.5 second; e.g. 120 units of 0.5 seconds = 60 seconds. However, it is more intuitive to enter time in the hh:mm:ss format, such as 00:01:00 for 1 minute or 60 seconds in the above example.

## 6.4.7 Setting the Date and Time

**Table K — Setting the Date and Time**

Enter command	UPS display	Description
<b>clock</b> and press <b>Enter</b>	*clock=12/31/07 22:00:00	Returns the current date and time.
<b>clock=010107 _ 120000</b> and press <b>Enter</b>	*clock=01/01/07 12:00:00 <sup>†</sup>	Sets the date and time to Jan 01, 2007, 12:00 pm.
<p>Notes:</p> <ol style="list-style-type: none"> <li>1. Time is displayed in the 24 hours clock format.</li> <li>2. Changing the mm/dd/yy format with DATE SEL on the LCD Control menu does not change the RS-232 mm/dd/yy format.</li> <li>3. If the Alpha Micro Secure has been in storage or switched off for a prolonged period, the backup Lithium coin battery could be drained and may not correctly keep a backup of the date and time you entered. After switching on the Alpha Micro Secure check the date and time settings. The Alpha Micro Secure should display the current date and time. If it displays the date as "00:01:00", then the battery is spent and you need to ask a qualified service personnel to replace the lithium coin battery. See "Troubleshooting".</li> </ol> <p>* Indicates that the Alpha Micro Secure has responded to the command you entered.</p> <p>† If the date or time change is invalid, the Alpha Micro Secure will return the time and date it was set to before you tried making the change. The date and time must be entered as one complete line command. You cannot change only the time or the date alone. Both must be set at the same time. If you make a mistake, press <b>Enter</b> and try again.</p>		

### 6.4.8 Viewing the Serial Number

To display the serial number of the Alpha Micro Secure UPS, type `*QY0` at the command line and press "Enter".

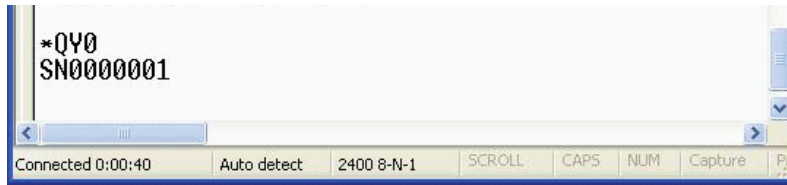

### 6.4.9 Setting the Peukert Number and Capacity

You can set the Peukert Number and Capacity using the RS-232 interface or the web interface. To display the current Peukert Number, type `*QY6` at the command line and press "Enter".

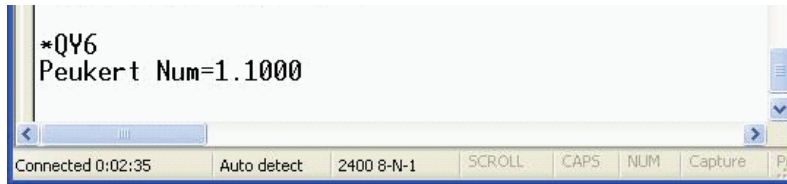

To change the Peukert Number to 1.1345, type `*ST6:1.1345` at the command line and press "Enter".

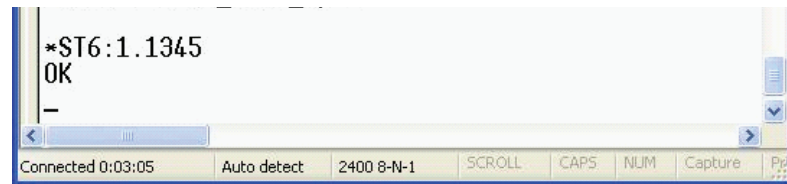

To display the current Peukert Capacity, type `*QY7` at the command line and press "Enter".

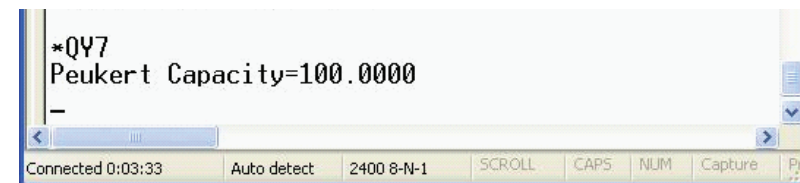

To change the Peukert Capacity to 109.123, type `*ST7:109.123` at the command line and press "Enter".

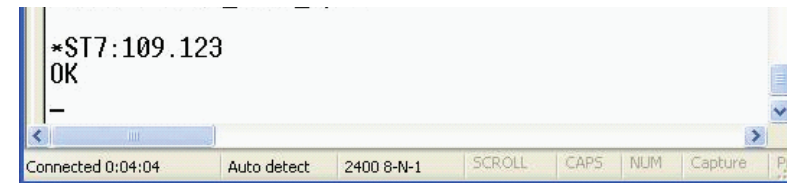

To determine the Peukert number and capacity of your battery, refer to "Peukert Number and Battery Capacity".

### 6.4.10 100-Event Log

Up to 100 events are stored in the Alpha Micro Secure’s log. If more than 100 events occur, the oldest is overwritten.

#### Procedure

- To see the log, type **event** (all lower case) and press **Enter**. The events are listed starting with the most recent and appear as: If less than 100 events occurred, the last entry will appear as:

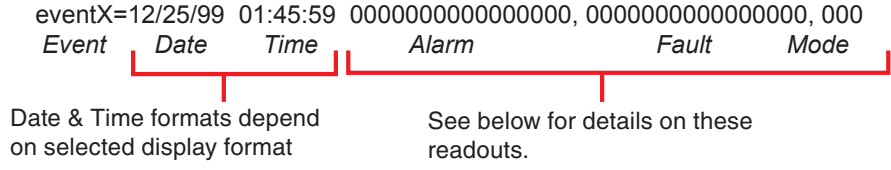

Alarm: When the following bits show a 1, the following alarms are displayed.

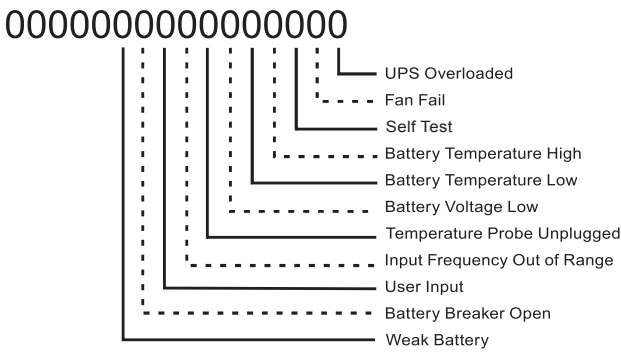

Fault: When the following bits show a 1, the following faults are displayed..

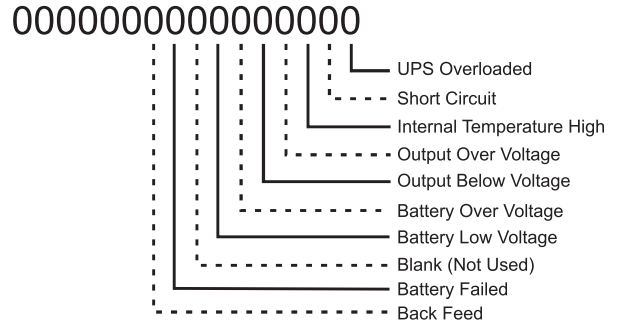

Code	Mode	Code	Mode	Code	Mode
000	Standby	003	Boost 1	006	Inverter
001	Line	004	Buck 1	009	Shutdown
002	Boost 2	005	Buck 2	010	Bypass

- If less than 100 events occurred, the last entry will appear as:  

```
eventX=00/00/00 00:00:00 0000000000000000, 0000000000000000, 000
```
- To clear the log, type **eventclr** and press **Enter**. It takes the Alpha Micro Secure 30 seconds to clear the log. Do not enter any other commands during this time.
- To see a specific event, type **eventX** where X is from 1 to 100 and press **Enter**. To see a range of events (for example, events 20 to 30), type **eventX-X** where X are events from 1 to 100 and press **Enter**.



## 6.4.11 Communicating with the Alpha UPS Monitor

### Introduction

The Alpha UPS Monitor graphical user interface (GUI) provides web or Windows® like computer communications with the Alpha Micro Secure. The screen and its features are shown below. It is used to monitor, control and set various parameters like the date and time, determine when to perform the weekly self test, change the relay configurations, etc. The Fault or Alarm indicators show if the Alpha Micro Secure has experienced a malfunction and the cause. Descriptions of all the screens and their functions are given in “Operation”.

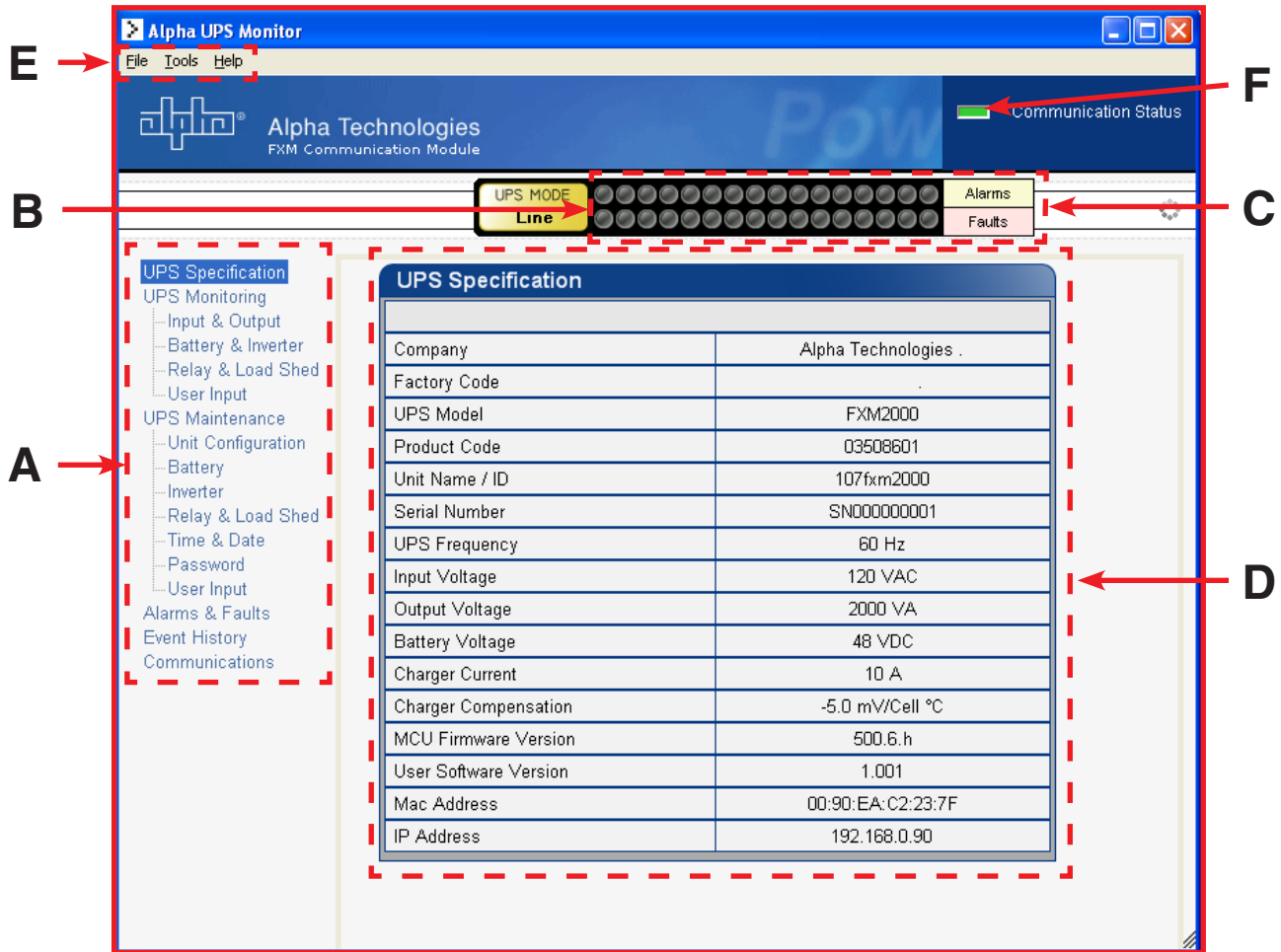

Figure 14 — Alpha UPS Monitor (UPS Specification Screen shown)

<b>A</b>	Screen selection menus.
<b>B</b>	Current UPS operating mode. This is updated automatically.
<b>C</b>	Fault and alarm indicators – when a light in this bar is illuminated, move the mouse cursor over the light to determine the malfunction. Double-clicking on the light will send you to the Alarms & Faults screen.
<b>D</b>	Readout screens.
<b>E</b>	Drop-down menus.
<b>F</b>	Online indicator.

## 6.4.12 Checking Your Windows Computer for the .NET Framework

1. Click on the **Start** button.
2. Go to and click on **Settings**.
3. Click on **Control Panel**.
4. Double-click on the **Add or Remove Programs** icon.
5. When the window shown in the figure below appears, scroll through the list of applications. If you see Microsoft .NET Framework listed, the Framework is already installed and you can install the Alpha UPS Monitor. If you don't see it listed, you MUST install it from the Microsoft Windows update web site before installing the software.

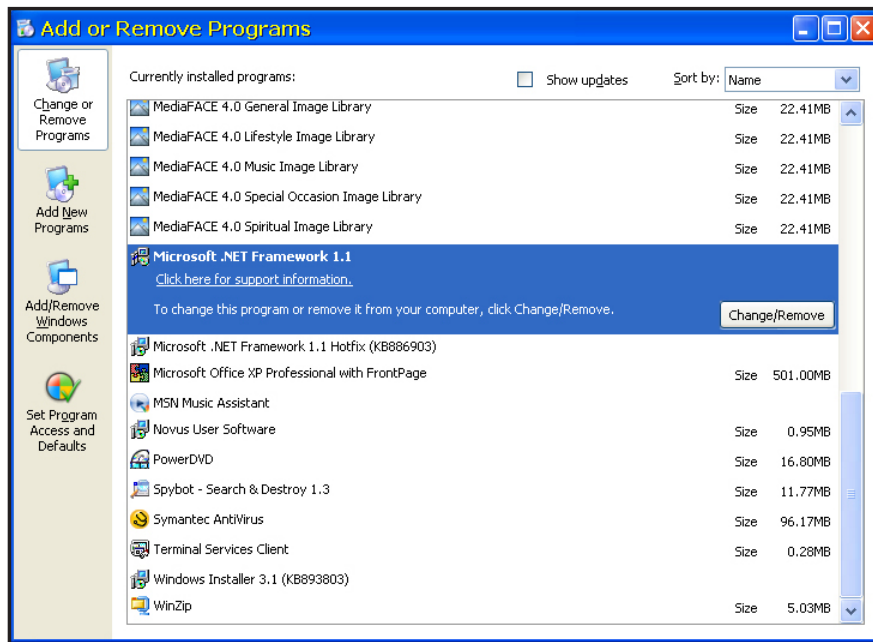

Figure 15 — Add or Remove Programs Window

If you are downloading from Microsoft's web site, an Internet web browser such as Internet Explorer or Firefox must be installed on your computer. In addition to installing .NET, downloading from the web site will update your computer with all the latest security updates. If your computer is part of a company network, check with your network administrator before downloading software from the Internet.

### 6.4.13 Installation and Set Up

The following tools and materials are required:

- Alpha UPS Monitor, available for download from [www.alpha.ca./downloads/](http://www.alpha.ca./downloads/).
- Windows 98 or later with Microsoft's .NET framework installed.
- DE-9 serial straight-through computer cable.

#### Procedure

1. Install the Alpha UPS Monitor onto your computer. Restart the computer.

If you install the Alpha UPS Monitor on a version of Windows without the .NET framework installed, an error message saying the framework is not installed will appear. Install the framework onto your computer according to "Communicating With the Alpha UPS Monitor". Restart your computer and then try to install the Alpha UPS Monitor again.

2. Connect the computer cable from any available communications port on the computer to the RS-232 port on the Alpha Micro Secure's front panel. See "Wiring the RS-232 Port".
3. Set the communications parameters on your computer to:
  - a. COM Port: The COM port on your computer you have selected to use.
  - b. Baud Rate: 2400.
4. To start communications between the computer and the Alpha Micro Secure do one of the following:
  - a. Click on the screen's Online Indicator, or
  - b. In the **File** drop-down menu, click on **Connect to Alpha Micro Secure**

If the computer cannot connect to the Alpha Micro Secure a pop up screen appears asking you to check the wiring and that you are connected to the proper com port.

## 6.5 Operation

The various screens are described on the following pages and operate like Web or Windows-type screens. Point and click to change the various functions or fields.

The on line indicator shows if you are connected to the Alpha Micro Secure. The Alpha UPS Monitor automatically polls the Alpha Micro Secure to obtain its status. The default setting is polling once every 3 seconds, but you can change this in the **UPS Maintenance-Unit Configuration** screen in the **"Status Refresh Time"** menu.

If a light or lights are illuminated in the Fault or Alarm fields, the Alpha Micro Secure has a malfunction. Hover your mouse cursor over the light to learn the type of malfunction or double-click on it to go straight to the Alarms & Faults screen.

To control the unit or change its settings or parameters, either click on the On/Off buttons, or choose an item from a drop down menu. Then click on the **Update Settings** button.

If you do not click on this button, the change will not happen.

### 6.5.1 UPS Specifications

This screen displays the various specifications of the Alpha Micro Secure

UPS Specification	
Company	Alpha Technologies .
Factory Code	
UPS Model	FXM2000
Product Code	03508601
Unit Name / ID	107fxm2000
Serial Number	SN000000001
UPS Frequency	60 Hz
Input Voltage	120 VAC
Output Voltage	2000 VA
Battery Voltage	48 VDC
Charger Current	10 A
Charger Compensation	-5.0 mV/Cell °C
MCU Firmware Version	500.6.h
User Software Version	1.001
Mac Address	00:90:EA:C2:23:7F
IP Address	192.168.0.90

Figure 16 — Alpha UPS Monitor: UPS Specification screen

## 6.5.2 UPS Monitoring

These read-only screens show the Alpha Micro Secure's current input and output values and other measurements.

### Input & Output

Shows the current line input and Alpha Micro Secure output values and the Alpha Micro Secure's present operating mode.

Input Parameters	
Voltage	109 VAC
Frequency	60 Hz
Mode	Boost 1

Output Parameters	
Voltage	124 VAC
Frequency	60 Hz
Current	0 A
Power	0 VA
Power Factor	0.0
Power Meter	0 kWh

Figure 17 — UPS Monitoring: Input & Output screen

### Battery & Inverter

Shows the battery string's status and how many times and for how long the inverter has been active.

Battery Parameters	
Battery Voltage	46.5 VDC
Charging Current	0.0 A
Runtime Remaining	5hr 10min
External Temperature	19 °C
Peukert Number	1.1000
Capacity	100.00 aH
Battery Open-Circuit Voltage	53.46

Inverter Parameters	
Accumulated Line Failures	50 Times
Accumulated Backup Time	4hr 12min

Figure 18 — UPS Monitoring: Battery & Inverter screen

## Relay & Load Shed

Shows how the front panel dry contacts are configured. If any relays are used for load shedding, the time setting is shown.

The screenshot displays the 'Relay & Load Shed' configuration screen. The left sidebar menu includes: UPS Specification, UPS Monitoring (Input & Output, Battery & Inverter, **Relay & Load Shed**, User Input), UPS Maintenance (Unit Configuration, Battery, Inverter, Relay & Load Shed, Time & Date, Password, User Input), Alarms & Faults, Event History, and Communications.

**Relay Programmable Status**

	Current	Function
Relay C1	Off	On Battery
Relay C2	Off	Low Battery
Relay C3	Off	Low Battery
Relay C4	Off	Timer 1
Relay C5	On	Alarm
Relay C6	On	External VDC

**Load Shed Timer Status**

	Time Remaining
Timer 1	2hr 0min 0sec
Timer 2	2hr 0min 0sec
Timer 3	2hr 0min 0sec

**Time Of Day Action Status**

	Time Period 1	Time Period 2
Action Enabled	OFF	OFF
Start Time	03:00:00 PM	04:00:00 AM
End Time	04:16:00 PM	07:07:00 AM

Figure 19 — UPS Monitoring: Relay & Load Shed screen

## User Input Status

Shows the current status of the user programmable inputs 1 to 3.

The screenshot displays the 'User Input Status' configuration screen. The left sidebar menu includes: UPS Specification, UPS Monitoring (Input & Output, Battery & Inverter, Relay & Load Shed, **User Input Status**), UPS Maintenance (Unit Configuration, Battery, Inverter, Relay & Load Shed, Time & Date), Alarms & Faults, Event History, and Communications.

**User Input Current Status**

	Input 1	Input 2	Input 3
<b>Type</b>	Edge Trigger	Level Toggle	Edge Trigger
<b>Level</b>	Low	Low	Low
<b>Action #1</b>	Self Test	User Alarm On	Shutdown On
<b>Action #2</b>	None	User Alarm Off	Shutdown Off

Figure 20 — UPS Monitoring: User Input Status screen

### 6.5.3 UPS Maintenance

The UPS Maintenance screens are used to configure and adjust the Alpha Micro Secure to meet your operating needs. To change parameters, either click on the **On/Off** buttons or choose an item from a drop down menu. To execute the changes, click on the **Update Settings** button. If you do not click this button, the changes will not happen.

#### Unit Configuration

Is used to set the name, input, output and how often the GUI polls the Alpha Micro Secure

	Current	New	
Unit Name / ID	1111	<input type="text"/>	<input type="text"/>
Output Shutdown	Off	<input type="button" value="On"/>	<input type="button" value="Off"/>
Bypass Mode	Off	<input type="button" value="On"/>	<input type="button" value="Off"/>
Temperature in Fahrenheit	Off	<input type="button" value="On"/>	<input type="button" value="Off"/>
Power Quality or AVR	AVR	<input type="button" value="PQ"/>	<input type="button" value="AVR"/>
Sense - Normal or Generator	Normal	<input type="button" value="Normal"/>	<input type="button" value="Generator"/>
Frequency	60 Hz	<input type="text" value="60"/>	
Rated Input Voltage	120 VAC	<input type="text" value="120"/>	
Line Qualify Time	3sec	<input type="text" value="3"/>	
Status Refresh Time	3sec	<input type="text" value="3"/>	

Restore Defaults      Update Configuration

Figure 21 — UPS Maintenance: Unit Configuration screen

#### Battery

Allows adjustments of battery string voltage, charging parameters, low battery warning time, periodic self test time, and starts the self test.

- UPS Specification
- UPS Monitoring
  - Input & Output
  - Battery & Inverter
  - Relay & Load Shed
  - User Input
- UPS Maintenance
  - Unit Configuration**
  - Battery
  - Inverter
  - Relay & Load Shed
  - Time & Date
  - Password
  - User Input
- Alarms & Faults
- Event History
- Communications

#### Battery Test

	Current	New	
Test	Off	<input type="button" value="On"/>	<input type="button" value="Off"/>
Test Depth-of-discharge	9 %	<input type="text" value="9"/>	

#### Auto Battery Test Settings

	Current	New	
Enable Auto Battery Test	Off	<input type="button" value="On"/>	<input type="button" value="Off"/>
Day	Monday	<input type="text" value="Monday"/>	
Time (hh-mm-ss)	12:00:00 AM	<input type="text" value="12"/>	<input type="text" value="00"/>
		<input type="button" value="PM"/>	<input type="button" value="AM"/>
Test Interval In Week	4	<input type="text" value="4"/>	

#### Battery Configuration

	Current	New
Charger Compensation	-2.5 mV/Cell/°C	<input type="text" value="-2.5"/>
Charging Current	2 A	<input type="text" value="2"/>
Low Battery Warning	3 %	<input type="text" value="3"/>
Peukert Number	1.0000	<input type="text" value="1.0000"/>
Capacity	100.00 Ah	<input type="text" value="100.00"/>
Battery Open-Circuit Voltage	54.20 VDC	<input type="text" value="54.20"/>

Figure 22 — UPS Maintenance: Battery screen

An accurate battery runtime estimation requires the following parameter to be adjusted:

- **Peukert Number:** Refer to the appendix for information about how to calculate the Peukert number to be entered here.
- **Battery Capacity:** This is the rated capacity (Ah) of the battery shown on the battery data sheet. Do not confuse the battery capacity with the Peukert capacity.
- **Battery Open Circuit Voltage:** This number is obtained from the battery data sheet. The battery data sheet shows the value for a single battery, so for a 48 V system where 4 batteries are connected in series, this number must be multiplied by four.

The "Battery Runtime Remaining" algorithm attempts to calculate the health of the battery to get a more accurate prediction of the remaining battery runtime. An accurate estimate of the battery health requires that at least one battery discharge greater than 20% depth of discharge has taken place since the unit was switched on. When the unit is powered up from an off state, the algorithm assumes that a new battery is connected to the unit. Each discharge of greater than 20% will result in a new calculation for the relative battery health. This value is then used in the "Battery Runtime Prediction algorithm to compensate for an aging battery. We recommend that the user set up a periodic (every 6 months) battery test with a depth of discharge of at least 20%.

The "Battery Runtime Remaining" algorithm relies heavily on the battery voltage to predict the remaining runtime. This results in a less accurate predicted runtime during periods when the battery voltage is changing rapidly. The battery voltage typically changes rapidly during the first few minutes of discharge when the unit switches from charging to discharging while the unit is in the Inverter mode. The battery voltage may also change rapidly during the last 20% of the discharge time when the battery is almost drained.

## Inverter

Is used to turn the inverter on or off to start or stop backup battery power to the load.

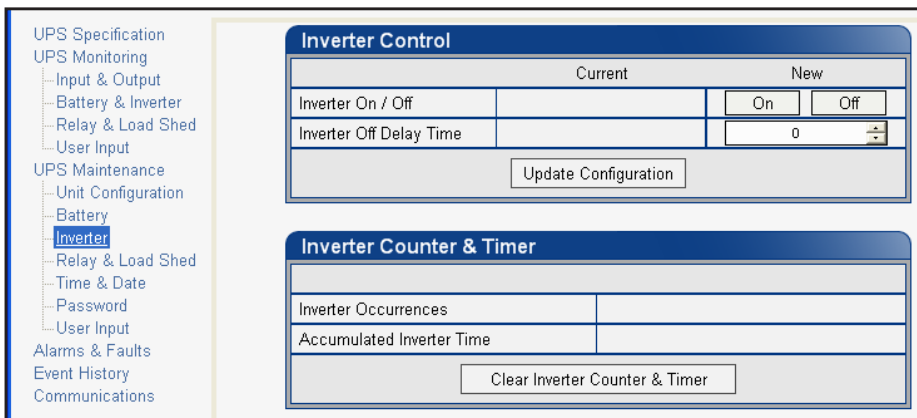

Figure 23 — UPS Maintenance: Inverter screen



## Relay & Load Shed

Is used to configure the front panel's dry contact to provide a signal for turning off the load.

The screenshot shows the 'Relay & Load Shed' configuration screen. On the left is a navigation menu with the following items: UPS Specification, UPS Monitoring, Input & Output, Battery & Inverter, Relay & Load Shed (highlighted), User Input, UPS Maintenance, Unit Configuration, Battery, Inverter, Relay & Load Shed (highlighted), Time & Date, Password, User Input, Alarms & Faults, Event History, and Communications.

**Relay Configuration**

Current	Action	New
Relay C1	On Off	On Battery
Relay C2	On Off	Low Battery
Relay C3	On Off	Timer 1
Relay C4	On Off	Temperature
Relay C5	On Off	Low Battery + No Line
Relay C6	On Off	Timer 2
Fan on Temperature		20

Update Configuration

**Load Shed Timer Configuration**

Time Remaining	Time Set
Timer 1	2 0 0
Timer 2	2 0 0
Timer 3	2 0 0

Update Configuration

**Time Of Day Action Configuration**

	Time Period 1	Time Period 2
Action Enabled	ON	OFF
Start Time	6 10 AM PM	8 10 AM PM
End Time	8 10 AM PM	10 20 AM PM

Update Configuration

Figure 24 — UPS Maintenance: Relay & Load Shed screen

### Controlling the external fan by temperature triggered dry contact

The Alpha Micro Secure has up to 6 dry contacts (C1 to C6) on the front panel which can be configured by the user to open or close based on the specific trigger conditions. Dry contact functions currently available include: Alarm, Fault, Timer, Low Battery, On Battery, etc. The Temperature trigger has been added as a new function, with a user configurable range of +20°C to +55°C. When the battery temperature (monitored by the Battery Temperature Probe) reaches the threshold, the assigned relay closes and turns on the external fan.

Dry contact C6 is by default factory hard wired to External VDC. To configure C6 as a programmable dry contact, the unit must be sent back to the factory.

The Temperature trigger can be programmed via one of the following 3 interfaces:

1. LCD panel – from the Logo screen, navigate to **Control Menu > RELAY TEMP**. Press the **SELECT** button and the current temperature display will start flashing. Use the **Scroll** button to change the temperature in 5°C increments. Press **SELECT** to accept the changes or **CANCEL** to abort.

<b>RELAY TEMP</b>	<b>120/60/N</b>
<b>55</b>	<b>LINE</b>

Dry contact functions are not programmable through the LCD. Use the RS-232 GUI or the HyperTerminal instead.

2. RS-232 GUI – Figure 25a shows the Relay Configuration window under the UPS Maintenance > Relay & Load Shed screen. As an example, to assign C1 as the Temperature trigger, select Temperature from the drop down menu. Click Update Configuration and the current status will update momentarily. In the example shown below, the fan on temperature threshold is set at 55°C. To change this value, simply type the new value into the Fan On Temperature box (or use the up/down arrow keys) and click Update Configuration to update the current status display.

a. Assigning the Temperature trigger function to a dry contact.

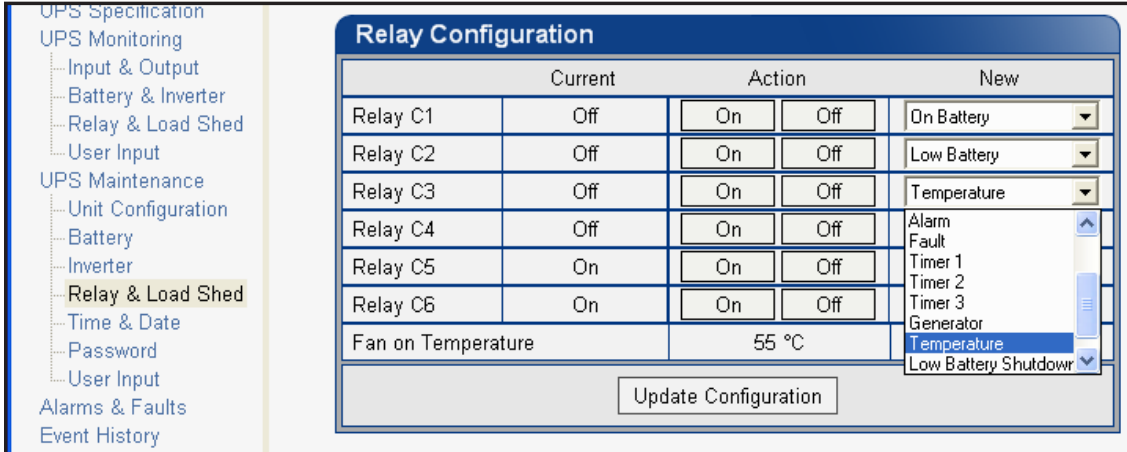

b. Setting the Temperature trigger value.

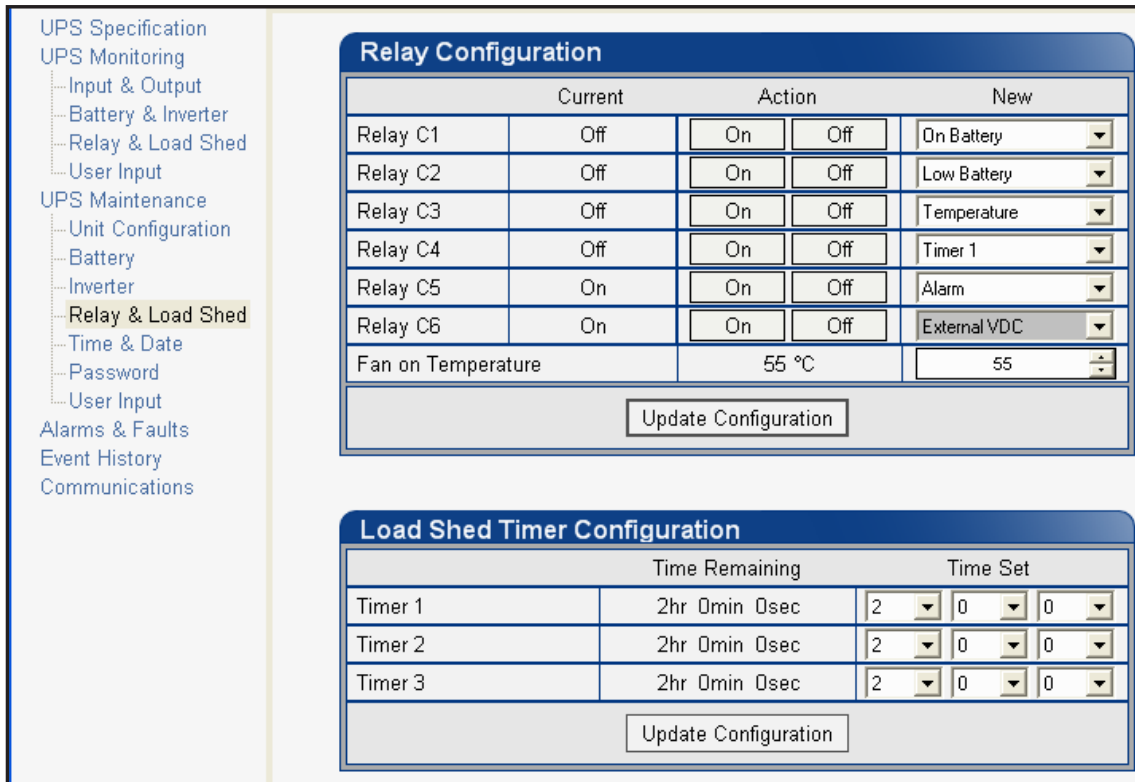

Figure 25 — Temperature trigger function via Alpha UPS Monitor

- RS-232 HyperTerminal – the Temperature trigger function can be assigned to any available dry contacts as described in "Programming the Dry Contacts" (e.g. c1=11, where 11 is the assigned index for the Temperature trigger function.)  
After establishing an RS-232 connection with the Alpha Micro Secure at the HyperTerminal screen prompt, type Temp and press Enter to display the current temperature setting Alpha Micro Secure returns \*temp=20). To change the value to +35°C, type temp=35 and press Enter. The Alpha Micro Secure returns \*temp=35 as confirmation.

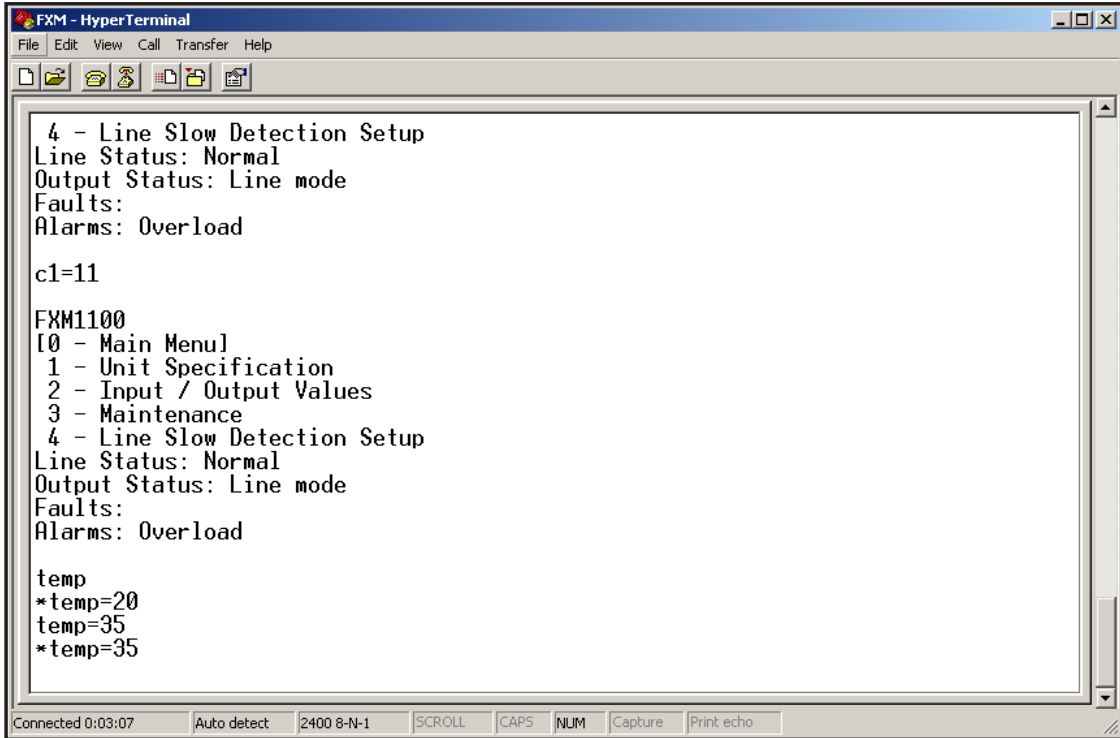

Figure 26 — Temperature trigger function via HyperTerminal

### Programmable Dry Contact Time of Day Action

You can assign a dedicated timer to a dry contact. Upon entering the Inverter operating mode, the timer is activated and begins to count down from a user defined value. When the timer reaches zero, the programmed dry contact relay will be activated (Status = ON).

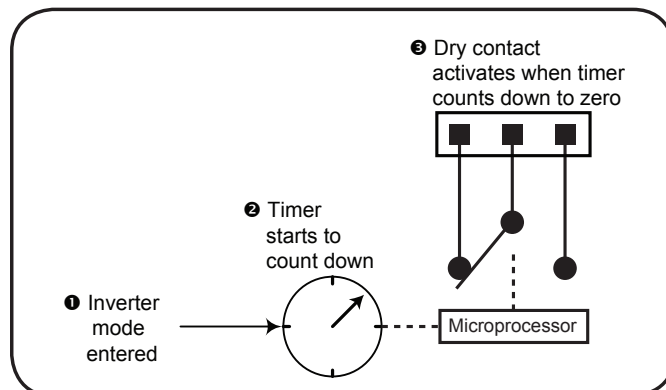

Figure 27 — Programmable Timer Operation

A typical application of this timer controlled dry contact function is to control a traffic light. When the grid power fails, the Alpha Micro Secure goes into the Inverter mode and continues supplying backup power to the traffic light. Since the batteries supplying the backup power have limited capacity, a timer controlled dry contact is usually configured to switch the traffic light into the flashing amber or flashing red mode after a user-defined period to conserve battery power. This setup works fine during non rush hour traffic, but during rush hour, it may be more desirable to keep the traffic light running normally for as long as backup power is available. To address this issue, a new feature called the **Time of Day Action** has been added to deactivate the timer during a user defined time period up to twice each day.

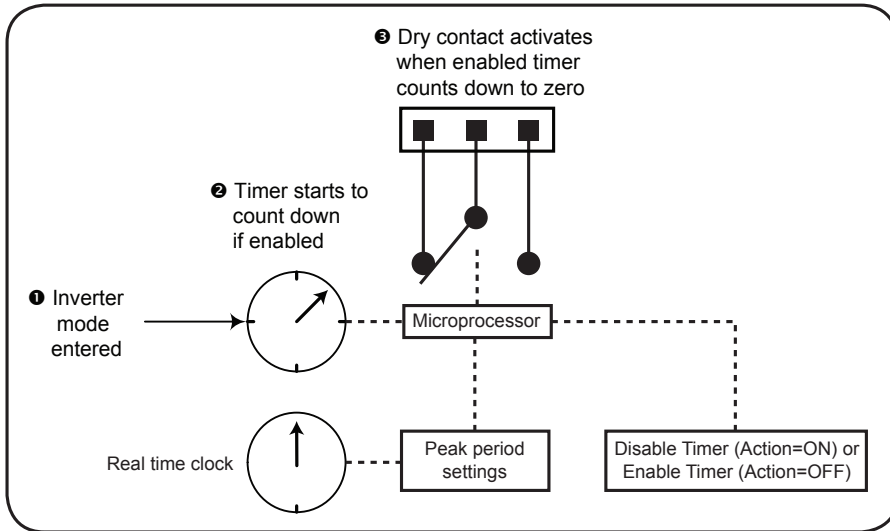

Figure 28 — Time Of Day Action Operation

You can define up to 2 peak time periods of the day:

1. Go to the UPS Maintenance > Relay & Load Shed screen.
2. In the Time of Day Action Configuration dialogue box, set up the start and end time of the first rush hour under Time Period 1 and the second rush hour under Time Period 2. In this example, during the first time period (7 AM to 9 AM), all 3 timers are disabled (they do not count down at all). Similarly, all timers are disabled during the second time period (3 PM to 6 PM).
3. Select ON under each time period. Click the Update button under each time period to store the settings. Confirm your settings in the UPS Monitoring > Relay & Load Shed > Time of Day Action Status screen.

Figure 29 — Time Of Day Configuration

<ul style="list-style-type: none"> <li>UPS Specification</li> <li>UPS Monitoring <ul style="list-style-type: none"> <li>Input &amp; Output</li> <li>Battery &amp; Inverter</li> <li><b>Relay &amp; Load Shed</b></li> <li>User Input Status</li> </ul> </li> <li>UPS Maintenance <ul style="list-style-type: none"> <li>Unit Configuration</li> <li>Battery</li> <li>Inverter</li> <li>Relay &amp; Load Shed</li> <li>Time &amp; Date</li> <li>Password</li> <li>User Input</li> </ul> </li> <li>Alarms &amp; Faults</li> <li>Event History</li> <li>Upgrade Files</li> <li>Communications</li> </ul>	<div style="border: 1px solid black; padding: 5px;"> <h3 style="text-align: center; background-color: #4F81BD; color: white; margin: 0;">Relay Programmable Status</h3> <table border="1" style="width: 100%; border-collapse: collapse;"> <thead> <tr> <th style="width: 30%;"></th> <th style="width: 35%;">Current Status</th> <th style="width: 35%;">Function</th> </tr> </thead> <tbody> <tr><td>Relay C1</td><td>Off</td><td>Timer 1</td></tr> <tr><td>Relay C2</td><td>Off</td><td>Timer 2</td></tr> <tr><td>Relay C3</td><td>Off</td><td>Timer 3</td></tr> <tr><td>Relay C4</td><td>Off</td><td>Disabled</td></tr> <tr><td>Relay C5</td><td>Off</td><td>Disabled</td></tr> <tr><td>Relay C6</td><td>On</td><td>External VDC</td></tr> </tbody> </table> </div> <div style="border: 1px solid black; padding: 5px;"> <h3 style="text-align: center; background-color: #4F81BD; color: white; margin: 0;">Load Shed Timer Status</h3> <table border="1" style="width: 100%; border-collapse: collapse;"> <thead> <tr> <th style="width: 30%;"></th> <th style="width: 35%;">Time Remaining</th> <th style="width: 35%;">Relay Mapping</th> </tr> </thead> <tbody> <tr><td>Timer 1</td><td>2hr 0min 0sec</td><td>C1</td></tr> <tr><td>Timer 2</td><td>2hr 0min 0sec</td><td>C2</td></tr> <tr><td>Timer 3</td><td>2hr 0min 0sec</td><td>C3</td></tr> </tbody> </table> </div> <div style="border: 1px solid black; padding: 5px;"> <h3 style="text-align: center; background-color: #4F81BD; color: white; margin: 0;">Time Of Day Action Status</h3> <table border="1" style="width: 100%; border-collapse: collapse;"> <thead> <tr> <th style="width: 30%;"></th> <th style="width: 35%;">Time Period 1</th> <th style="width: 35%;">Time Period 2</th> </tr> </thead> <tbody> <tr><td>ON/OFF</td><td>ON</td><td>ON</td></tr> <tr><td>Start At</td><td>7:0</td><td>15:0</td></tr> <tr><td>End At</td><td>9:0</td><td>18:0</td></tr> </tbody> </table> </div>		Current Status	Function	Relay C1	Off	Timer 1	Relay C2	Off	Timer 2	Relay C3	Off	Timer 3	Relay C4	Off	Disabled	Relay C5	Off	Disabled	Relay C6	On	External VDC		Time Remaining	Relay Mapping	Timer 1	2hr 0min 0sec	C1	Timer 2	2hr 0min 0sec	C2	Timer 3	2hr 0min 0sec	C3		Time Period 1	Time Period 2	ON/OFF	ON	ON	Start At	7:0	15:0	End At	9:0	18:0
	Current Status	Function																																												
Relay C1	Off	Timer 1																																												
Relay C2	Off	Timer 2																																												
Relay C3	Off	Timer 3																																												
Relay C4	Off	Disabled																																												
Relay C5	Off	Disabled																																												
Relay C6	On	External VDC																																												
	Time Remaining	Relay Mapping																																												
Timer 1	2hr 0min 0sec	C1																																												
Timer 2	2hr 0min 0sec	C2																																												
Timer 3	2hr 0min 0sec	C3																																												
	Time Period 1	Time Period 2																																												
ON/OFF	ON	ON																																												
Start At	7:0	15:0																																												
End At	9:0	18:0																																												

Figure 30 — Time Of Day Action Status

Once the Time of Day Action is configured, the Alpha Micro Secure will automatically disable the timers during the Inverter mode at the defined peak periods.

You can switch off the Time of Day Action by setting one or both time period(s) to **OFF**. The dry contact will be activated by the timer regardless of the peak period settings.

## Time & Date

Is used to set the Alpha FXM's date and time.

<ul style="list-style-type: none"> <li>UPS Specification</li> <li>UPS Monitoring <ul style="list-style-type: none"> <li>Input &amp; Output</li> <li>Battery &amp; Inverter</li> <li>Relay &amp; Load Shed</li> <li>User Input</li> </ul> </li> <li>UPS Maintenance <ul style="list-style-type: none"> <li>Unit Configuration</li> <li>Battery</li> <li>Inverter</li> <li>Relay &amp; Load Shed</li> <li><b>Time &amp; Date</b></li> <li>Password</li> <li>User Input</li> </ul> </li> <li>Alarms &amp; Faults</li> </ul>	<div style="border: 1px solid black; padding: 5px;"> <h3 style="text-align: center; background-color: #4F81BD; color: white; margin: 0;">Time and Date Settings</h3> <table border="1" style="width: 100%; border-collapse: collapse;"> <thead> <tr> <th style="width: 40%;"></th> <th style="width: 30%;">Current</th> <th style="width: 30%;">New</th> </tr> </thead> <tbody> <tr> <td colspan="3"><input type="checkbox"/> Synchronize Time with Computer</td> </tr> <tr> <td>24 Hour Clock</td> <td>Off</td> <td>On <input type="button" value="Off"/></td> </tr> <tr> <td>Daylight Savings Time</td> <td>Off</td> <td>On <input type="button" value="Off"/></td> </tr> <tr> <td>Set Date</td> <td>2000-16-12</td> <td>December 16 2000</td> </tr> <tr> <td>Set Time</td> <td>09:50:59 PM</td> <td>09 50 31 AM <input type="button" value="PM"/></td> </tr> <tr> <td>Date Format</td> <td>YYYY-DD-MM</td> <td>YYYY-DD-MM</td> </tr> </tbody> </table> <p style="text-align: center;"><input type="button" value="Update Configuration"/></p> </div>		Current	New	<input type="checkbox"/> Synchronize Time with Computer			24 Hour Clock	Off	On <input type="button" value="Off"/>	Daylight Savings Time	Off	On <input type="button" value="Off"/>	Set Date	2000-16-12	December 16 2000	Set Time	09:50:59 PM	09 50 31 AM <input type="button" value="PM"/>	Date Format	YYYY-DD-MM	YYYY-DD-MM
	Current	New																				
<input type="checkbox"/> Synchronize Time with Computer																						
24 Hour Clock	Off	On <input type="button" value="Off"/>																				
Daylight Savings Time	Off	On <input type="button" value="Off"/>																				
Set Date	2000-16-12	December 16 2000																				
Set Time	09:50:59 PM	09 50 31 AM <input type="button" value="PM"/>																				
Date Format	YYYY-DD-MM	YYYY-DD-MM																				

Figure 31 — UPS Maintenance: Time & Date screen

## Password

Is used to set the Alpha Micro Secure's password. The factory set password is 1111.

Novus Password Configuration	
New Password	****
Confirm New Password	****
<input type="button" value="Change Password"/>	

Figure 32 — UPS Maintenance: Password screen

The password is limited to 4 alphanumeric characters. The software will not accept more than 4 characters.

## User Input

Three programmable User Inputs exist. Their functions are similar to the Dry Contact relays. Supported functions include: (a) Shutdown, (b) User Alarm and (c) Self Test.

	Input 1	Input 2	Input 3
Type	Edge Trigger	Edge Trigger	Level Toggle
Level	Low	Low	Low
Action #1	None	None	User Alarm On
Action #2	None	None	User Alarm Off
	<input type="button" value="Update"/>	<input type="button" value="Update"/>	<input type="button" value="Update"/>

Figure 33 — UPS Maintenance: User Input screen

Any user input can be configured to perform a certain action in response to different trigger types and logic levels. For example, if you want the Alpha Micro Secure to issue an intrusion alarm when the door is opened, you will need to wire the door with a switch that triggers a user input every time the door is opened. The following procedure describes how User Input 1 can be configured as an intrusion alarm input.

**Procedure**

1. Select **UPS Maintenance > User Input** to display the **User Input Configuration** window.

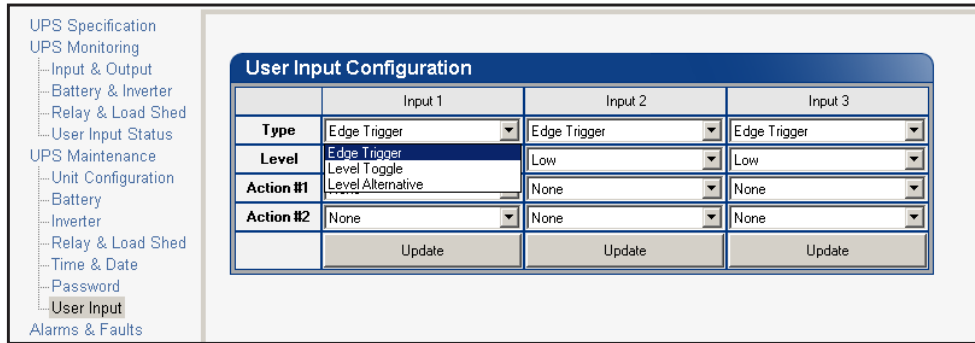

Figure 34 — User Input Configuration: Setting the Trigger Type

2. In the Input 1 column, select the **Type** down arrow to display the 3 types of available triggers: Edge Trigger, Level Toggle, and Level Alternative. For more information on how triggers work, see "Types of Trigger".
3. Select **Edge Trigger**.
4. Select **Low** from the **Level** drop down menu. The User Input will go to logic level "low" whenever it is triggered.

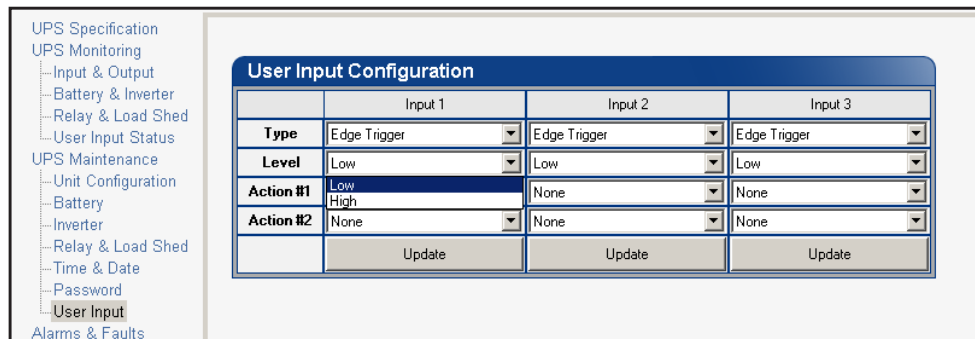

Figure 35 — User Input Configuration: Setting the Logic Level

5. Select **User Alarm On** from the **Action #1** drop down menu.

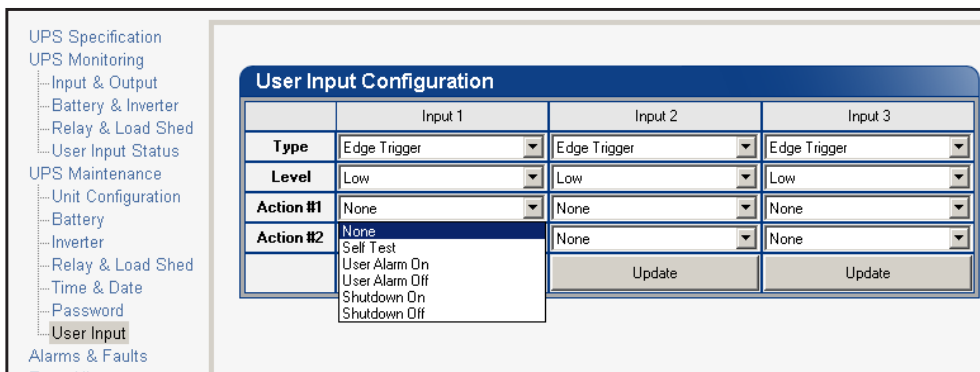

Figure 36 — User Input Configuration: Setting an Action

6. Click the **Update** button and enter the password to confirm if required.

7. Check the **User Input Current Status** at the **UPS Monitoring > User Input Status** page.

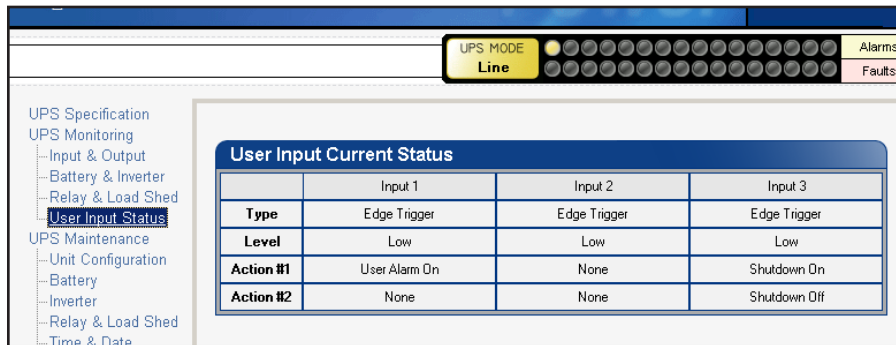

Figure 37 — User Input Current Status

Perform a quick test by shorting the User Input 1 dry contact pin (Pin 19 of C6) to ground (Pin 22 of C6) with a short length of PVC insulated electronic wire. This will trigger the Alpha Micro Secure to issue a User Input Alarm as shown below.

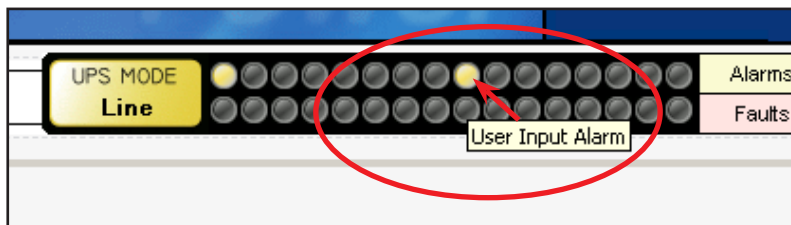

Figure 38 — User Input Current Status

Hovering the cursor over the amber indicator will display the corresponding context sensitive message.



## Operation

Many of the screens used for Ethernet communications look and function the same and contain the same information as the Alpha UPS Monitor screens. There are additional screens only available with Ethernet communications which are detailed below.

### Configure Site Information

This screen is used to enter site location information into the UPS's memory.

Alpha Technologies  
FXM Communication Module

UPS MODE  
Line

- UPS Specification
  - UPS Monitoring
  - UPS Maintenance
- Alarms & Faults
- Event History
  - Upgrade Files
- Configure Site Information**
- Communications

Site Information	
Site Name	FXM Supervisory
City	Burnaby
Prov./State/Region	B.C.
Country	Canada
Contact Name	Alpha Technical Support
Phone Number	604-430-1476

Apply Settings

Figure 39 — Alpha UPS Monitor: Configure Site Information

## Communications

- Configure TCP/IP is used to set the UPS's IP or TCP address.
- Configure SNMP is used to set the UPS for use with SNMP communications.
- Configure RS-232: You cannot change RS-232 parameters with this screen.
- Email Notification tells the card to send an e-mail message whenever selected UPS events happen.

Alpha Technologies  
FXM Communication Module

UPS MODE  
Line

- UPS Specification
  - UPS Monitoring
  - UPS Maintenance
- Alarms & Faults
- Event History
  - Upgrade Files
- Configure Site Information
- Communications
  - Configure TCP/IP**
  - Configure SNMP
  - Configure RS232
  - Email Notification

Internet Protocol (TCP/IP) Properties	
<input type="checkbox"/> Obtain an IP address automatically	
IP address	24.80.96.158
Subnet mask	255.255.252.0
Default gateway	24.80.96.1
<input type="checkbox"/> Obtain DNS server address automatically	
Preferred DNS server	64.59.144.18
Alternate DNS server	64.59.144.19

Apply Settings

Figure 40 — Alpha UPS Monitor: UPS Communications screen

## Restoring All Parameters to Default Values

The purpose of this command is to reset the Alpha Micro Secure to the factory default state. See Table P for a list of parameters that will be restored to their default values.



### CAUTION!

**This command resets all parameters that are user-configurable. All previously programmed operation will be lost. Implement a backup plan for mission critical operations. This command is password protected.**

The default command can be issued via the RS-232 HyperTerminal or the RS-232 GUI as follows:

- RS-232 HyperTerminal – type **default:all** and **press Enter**. **Enter the password and the** Alpha Micro Secure returns **\*default** as confirmation.
- RS-232 GUI – From the UPS Maintenance > Unit Configuration screen, click the Restore Defaults button. Enter the password to execute the command.

	Current Status	New Setting
Unit Name / ID	1111	<input type="text"/>
Output Shutdown	Off	<input type="button" value="On"/> <input type="button" value="Off"/>
Bypass Mode	Off	<input type="button" value="On"/> <input type="button" value="Off"/>
Power Quality or AVR	AVR	<input type="button" value="PQ"/> <input type="button" value="AVR"/>
Sense - Normal or Generator	Normal	<input type="button" value="Normal"/> <input type="button" value="Gen"/>
Frequency	60 Hz	<input type="text" value="60"/>
Rated Input Voltage	120 VAC	<input type="text" value="120"/>
Rated Output Voltage	120 VAC	<input type="text" value="120"/>
Line Qualify Time	3sec	<input type="text" value="3"/>
Status Refresh Time	4sec	<input type="text" value="3"/>

Figure 41 — Restore all default commands

<b>Table M — List of Parameters</b>
Maximum battery charging current
Temperature compensation of battery charging
Maximum allowable duration of output short circuit before shutdown
Property settings of programmable user input #1
Action #1 setting of programmable user input #1
Action #2 setting of programmable user input #1
Property settings of programmable user input #2
Action #1 setting of programmable user input #2
Action #2 setting of programmable user input #2
Property settings of programmable user input #3
Action #1 setting of programmable user input #3
Action #2 setting of programmable user input #3
Start hour of rush hour of time of day action period #1
Start minute of rush hour of time of day action period #1
End hour of rush hour of time of day action period #1
End minute of rush hour of time of day action period #1
Start hour of rush hour of time of day action period #2
Start minute of rush hour of time of day action period #2
End hour of rush hour of time of day action period #2
End minute of rush hour of time of day action period #2
Scheduled events
Format setting of date display on LCD
Line qualify time
Time setting of periodical self-test (minute) (hh:mm)
Inverter off delay setting
RS-232 baud rate
Number of weeks setting of periodical self-test
Day of the week setting of periodical self-test
Time of the day setting of periodical self-test
Battery low warning threshold setting (%)
Self test duration setting (minutes)
Internal temperature setting to turn on cooling fan
Load shed timer1 duration
Load shed timer2 duration
Load shed timer3 duration
Programmable dry contact #1 setting
Programmable dry contact #2 setting
Programmable dry contact #3 setting
Programmable dry contact #4 setting
Programmable dry contact #5 setting
Programmable dry contact #6 setting
Password setting

## Alarms & Faults

This read-only screen shows the operating status of the Alpha Micro Secure. When the fault or alarm indicators on the horizontal bar are illuminated, place the mouse cursor over the light to display the context sensitive message.

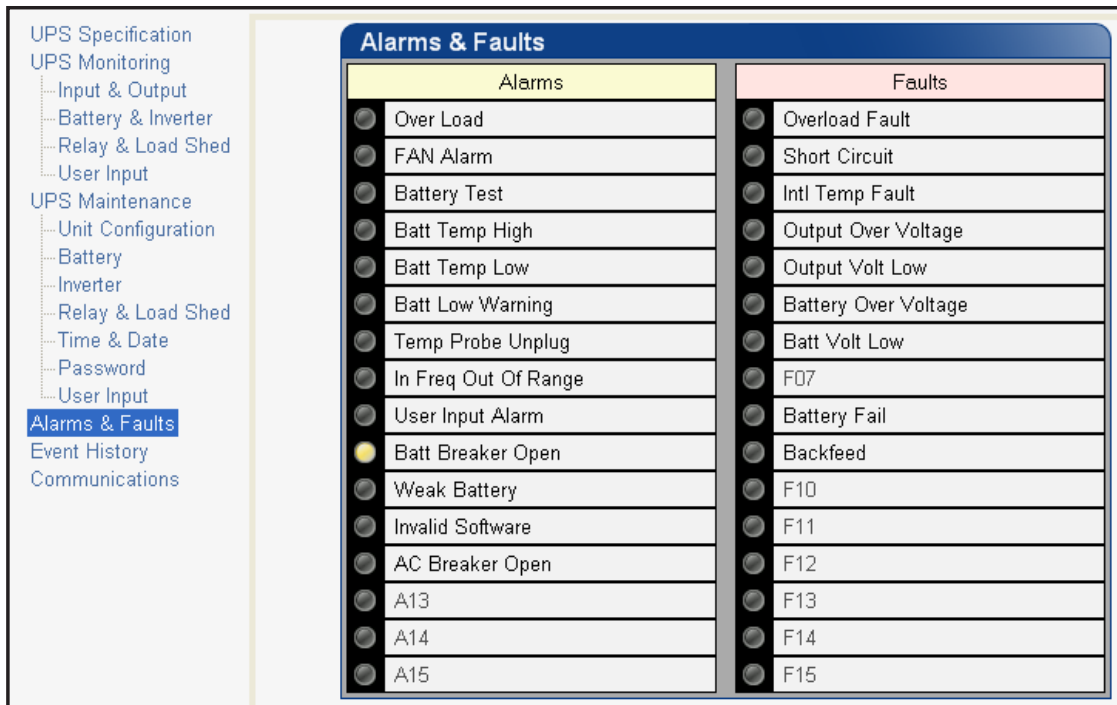

Figure 43 — Alpha UPS Monitor: UPS Alarms & Faults screen

## Event History

This screen shows the last 100 events recorded by the Alpha Micro Secure. Choosing a number in the **Event Index** drop-down box and then clicking on the **View Selected** button will display the updated information about the selected event.

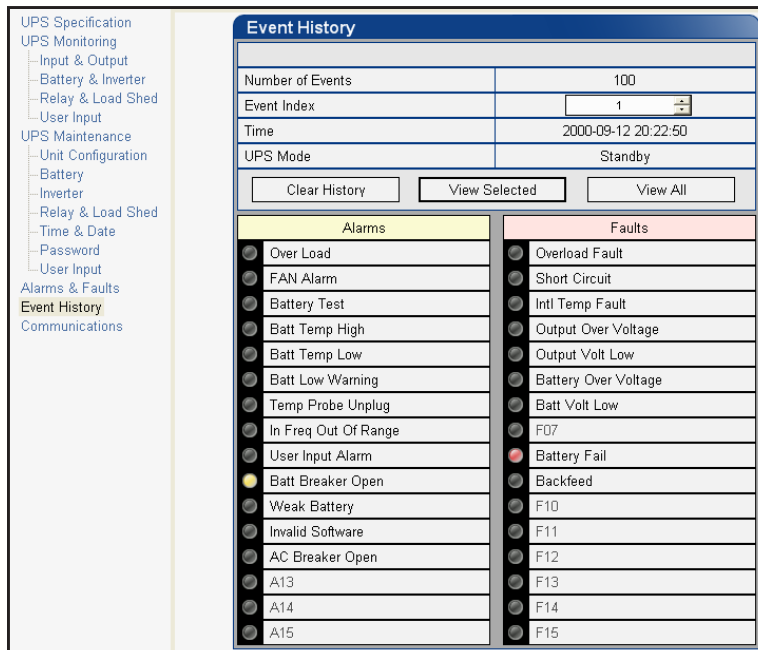

Figure 42 — Alpha UPS Monitor: UPS Event History screen

To view all the events, click on the **View All** button to open the **Event Log Monitor** window. Clicking on the **Clear History** button clears the log. This action cannot be undone.

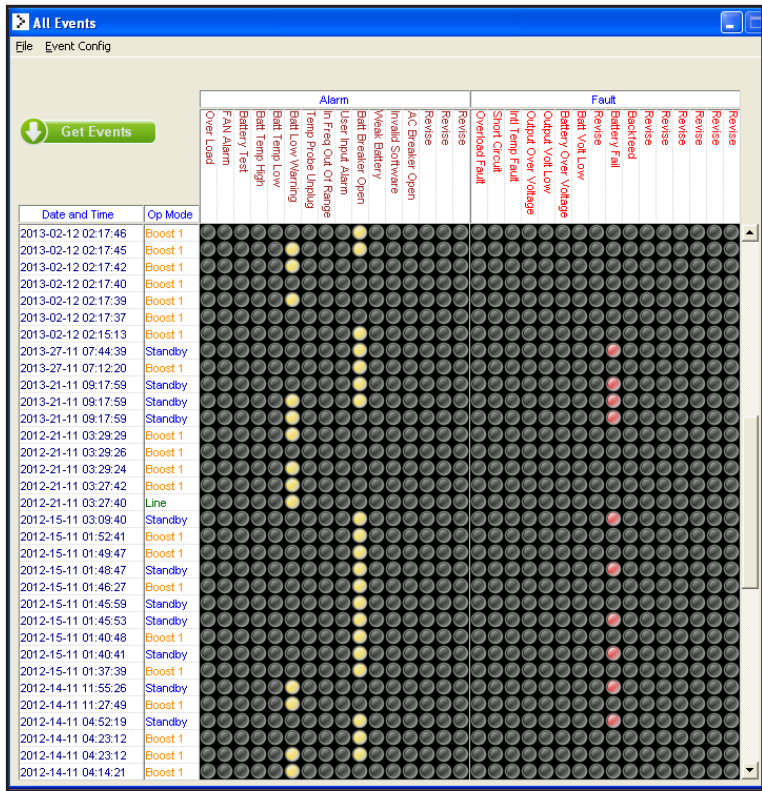

Figure 44 — Alpha UPS Monitor: Event Log Monitor screen

In the **Event Log Monitor** window, the events are displayed by date and time. Scroll up and down the list to select the events you want to see. To download the latest events from the Alpha Micro Secure click on the **Get Events** button. This process may take a few minutes. When the process is finished the events can be saved to an event file by selecting **File > Save As**.

To build a complete history of events for an Alpha Micro Secure save all the downloaded events from the unit to the same event file. A maximum of 100 events can be stored on the Alpha Micro Secure. The oldest events are replaced by the newest ones. However, saving to the same event file gives the option of appending to an existing event file when selecting **File > Save As**.

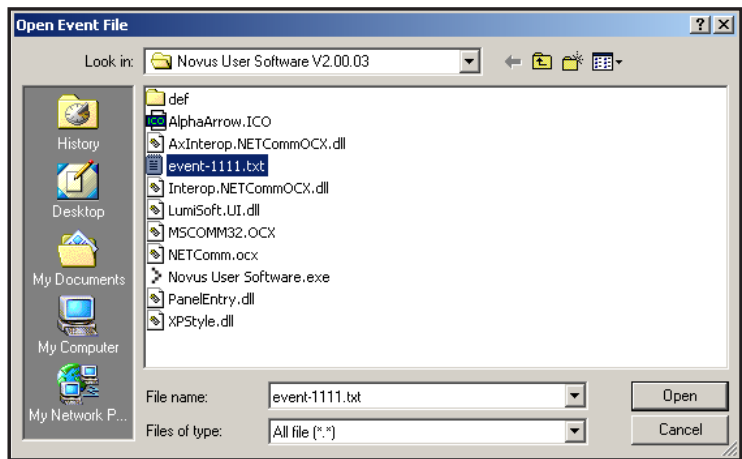

Figure 45 — Event Log Monitor, Open Event File window

To view a previously saved event log without downloading any new events from the Alpha Micro Secure and overwriting the saved event file, select **File > Open** and navigate to the saved event log file.

When opening or saving event log files, only files with the extension 'evt' can be opened or closed. This is the file type associated with event log files in the Alpha UPS Monitor.

## Upgrade Files

This feature is available only on Alpha Micro Secure UPS equipped with the network interface card factory option. To upgrade the Alpha UPS Monitor firmware, browse to the .bin file and click OK to start the upload. This may take a few minutes to complete.

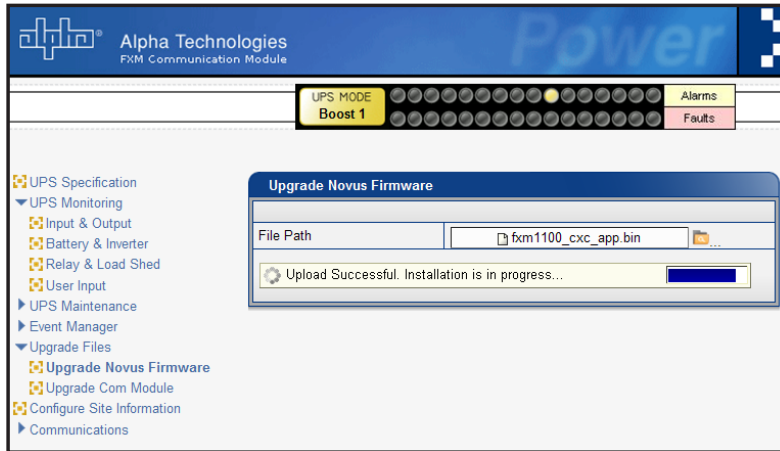

Figure 46 — Alpha UPS Monitor: Upgrade Firmware

To upgrade the Communication module, browse to the .ezip file and click OK to start the upload. This may take a few minutes to complete.

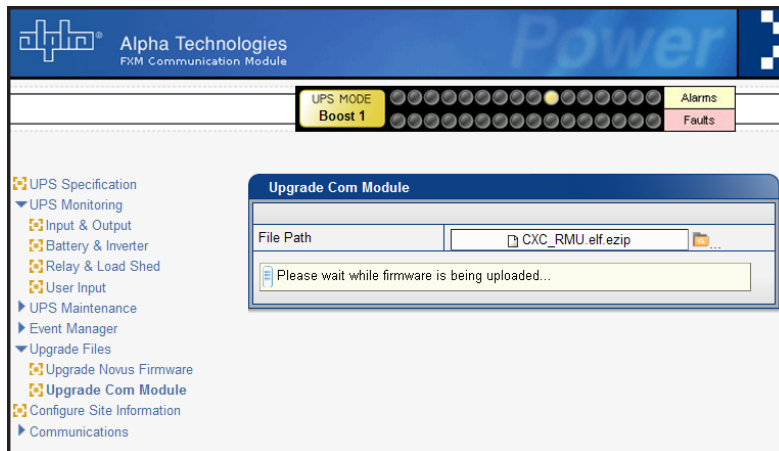

Figure 47 — Alpha UPS Monitor: Upgrade Communication Module

## Communications

This screen changes the Alpha Micro Secure's communication parameters. The RS-232 Baud Rate cannot be changed.

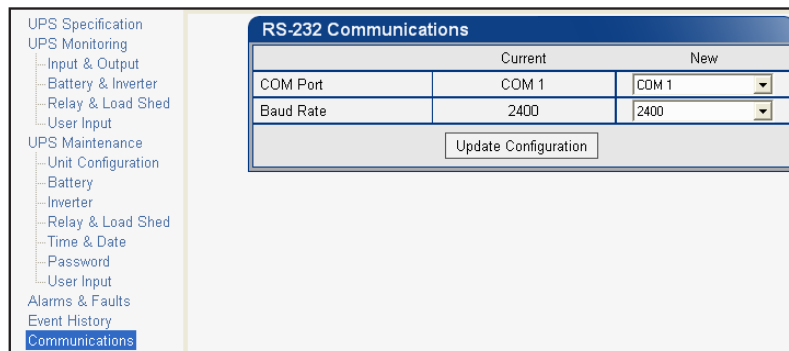

Figure 48 — Alpha UPS Monitor: UPS Communications screen

## Keep Alive

The Keep Alive feature can be used to reset power when a communication failure is detected. The purpose of the reset is to temporarily remove power and reset the local communications equipment powered by this unit. The goal of the Keep Alive feature is to attempt to restore communications by resetting the local communication equipment until communications is re-established

**Alpha Technologies**  
FXM Communication Module

UPS MODE: **Line** | Alarms | Faults

- UPS Specification
  - UPS Monitoring
    - Input & Output
    - Battery & Inverter
    - Relay & Load Shed
    - User Input
  - UPS Maintenance
    - Unit Configuration
    - Battery
    - Inverter
    - Relay & Load Shed
    - Time & Date
    - Password
    - User Input
  - Event Manager
    - Alarms & Faults
    - Event History
    - All Events
  - Upgrade Files
    - Upgrade Novus Firmware
    - Upgrade Com Module
  - Configure Site Information
    - Communications
      - Configure TCP/IP
      - Configure SNMP
      - Email Notification
    - Keep Alive**

### Keep Alive Status/Manual Control

Current		New	
Status	Ping Echo Received	<input type="checkbox"/> On	<input type="checkbox"/> Off
Delay To Startup	60 Sec	<input type="text" value="60"/>	
<a href="#">Update Configuration</a>			

### Keep Alive Method To Detect Communication Failure

Current		New	
Protocol	Ping	<input type="text" value="Ping"/>	
IP address	10.1.8.172	<input type="text" value="10.1.8.172"/>	
Delay Between Retry	5 Sec	<input type="text" value="5"/>	
<a href="#">Update Configuration</a>			

### How To Detect Communication Failure

Current		New	
Timeout	15 Sec	<input type="text" value="15"/>	
Retries Before Failure	3	<input type="text" value="3"/>	
<a href="#">Update Configuration</a>			

### Keep Alive Action To Attempt To Restore Communication

Current		New	
Action	Reset Power	<input type="text" value="Reset Power"/>	
Action Duration	30 Sec	<input type="text" value="30"/>	
<a href="#">Update Configuration</a>			

### When To Fail

Current		New	
After X Consecutive Actions	3	<input type="text" value="3"/>	
<a href="#">Update Configuration</a>			

### Keep Alive Failure

Current		New	
Send Trap	On	<input type="checkbox"/> On	<input type="checkbox"/> Off
Delay To Re-Startup	120 Sec	<input type="text" value="120"/>	
<a href="#">Update Configuration</a>			

**Keep Alive status/manual control:**

- a. The Status field allows the user to enable or disable the Keep Alive function. When disabled the alarm is cleared.
- b. The Delay to Startup field allows the user to set the time to the first ping from the enable ping or UPS restart after a ping failure. Minimum = 5 s, Maximum = 3600 s.

**Keep Alive Method to detect communication failure:**

- a. The Protocol field allows Ping as the only option.
- b. The IP Address field is used to enter the IP address to be pinged.
- c. The Delay Between Retry field is the delay between pings. Minimum = 5 s, Maximum = 65535 s.

**How to detect communication failure:**

- a. The Timeout field is where the ping time out setting is configured. Minimum = 2 s, Maximum = 65534 s.
- b. The Retries Before Failure field is the number of pings to repeat before power cycling. Minimum = 1, Maximum = 20.

**Keep Alive action to attempt to restore communication:**

- a. The Action field allows Reset Power as the only option.
- b. The Action Duration field is how long the output will be shut off by the UPS, Minimum = 1, s Maximum = 3600 s.

**When To Fail:**

- a. The After X Consecutive Actions field determines the number of times the UPS will go through the ping and power down and back up cycle before registering an Alarm for Keep Alive. Other alarms and events will occur regardless of this value. After the final power cycle, the UPS will issue another ping after the Delay between retry has elapsed. This ensures the destination IP is not alive. The UPS will then set the Keep Alive alarm. Minimum = 1, Maximum = 20.

**Keep Alive Failure:**

- a. The Send Trap field allows the email and SNMP trap notification to be switched on and off for the Keep Alive only.
- b. The Delay to Re-Startup field configures the delay after the Keep Alive alarm is set and the next ping is sent in delay to restart. Minimum = 5 s, Maximum = 3600 s.



## 6.6 Communicating Via The Intranet or Internet

If the Alpha Micro Secure is equipped with the optional, factory-installed communication module, then the internet or a company intranet can be used to communicate with the Alpha Micro Secure. In addition, the Alpha Micro Secure can be monitored and controlled via a web browser or with SNMP protocols.

### 6.6.1 Installation and Set Up

The following tools and materials are needed:

- Computer with network card and web browser.
- Cross over cable or hub.
- The UPS's: Final IP Address and Subnet Mask and if needed the Default Gateway and the DNS Server addresses.



#### **CAUTION!**

**To successfully complete this procedure, you should have a working knowledge of network protocols and how to configure them. Consult your network administrator for details.**

**If multiple UPS's are installed on the same network, configure each unit's IP address before the installation. Each UPS on the network MUST have its own unique IP address. See "Communications, Configure TCP/IP".**

### 6.6.2 Procedure

1. Connect the Alpha Micro Secure to the computer with either the cross over cable or a hub.
2. Switch on the computer.
3. Configure the network card to talk to the communication module. The module's default address is `http://192.168.0.90`.
4. Type the IP address into the browser and press ENTER. The input and output screen appears. See "UPS Monitoring".
5. Go to the communications screen, "Configure TCP/IP", and configure the TCP/IP properties according to your network's requirements. Push the Apply Settings button. The screen will prompt for the password. The factory default password is 1111.
6. Connect the Alpha Micro Secure to the configured network according to your new properties.
7. Access the Alpha Micro Secure according to the new network properties.

### 6.6.3 Types of Trigger

There are 3 types of trigger:

#### Edge trigger

When the user input changes from one state to the other, the Alpha Micro Secure is triggered to perform Action #1. If the level is set to High, the action will be triggered by a Low to High edge (leading edge). If the level is set to Low, the action will be triggered by the High to Low edge (falling edge).

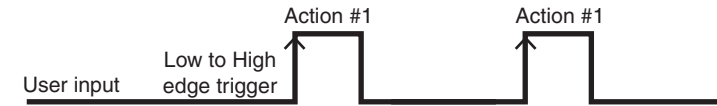

(a) Level = High  
 User Input = Low to High, Action #1 is triggered  
 User Input = High to Low, no action triggered



(b) Level = Low  
 User Input = High to Low, Action #1 is triggered  
 User Input = Low to High, no action triggered

Figure 49 — Edge Trigger

#### Level Toggle

When the Level is set to High, the Alpha Micro Secure is triggered to perform the other action when the user input changes from Low to High. If the input then changes from High to Low, Action #2 will be triggered. In other words, a level change in the user input will trigger an action toggle between Action #1 and #2.



(a) Level = High  
 User Input = Low to High, Action #1 is triggered  
 User Input = High to Low, Action #2 is triggered

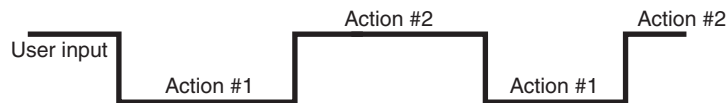

(b) Level = Low  
 User Input = High to Low, Action #1 is triggered  
 User Input = Low to High, Action #2 is triggered

Figure 50 — Level Trigger

## Level Alternative

When the level is set to High, the Alpha Micro Secure is triggered to perform the next action when the user input changes from Low to High. If the input then changes from High to Low, no action will be triggered because the level is set to High. In other words, only a Low to High user input level triggers an action when Level is set to High. Similarly, when Level is set to Low, the Alpha Micro Secure will trigger an action only with a High to Low user input.

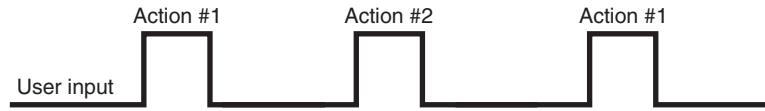

User Input = Low to High, Action #1 is triggered  
User Input = High to Low, no action triggered  
User Input = Low to High, Action #2 is triggered  
User Input = High to Low, no action triggered



User Input = High to Low, Action #1 is triggered  
User Input = Low to High, no action triggered  
User Input = High to Low, Action #2 is triggered  
User Input = Low to High, no action triggered

Figure 51 — Level Alternative

# 7. Maintenance

---

## 7.1 Updating the Software

The Alpha Micro Secure's firmware can be reinstalled or updated to the latest version with this procedure.

If your Alpha Micro Secure is provided with the factory-installed communication module, the firmware upgrade can be done via an intranet or internet connection.

You will need the following items:

- RS-232 connection cable to the Alpha Micro Secure
- **uBug12** software must be installed. It is available for download at [www.alpha.ca/downloads](http://www.alpha.ca/downloads).
- Alpha's firmware must be installed. It can be accessed with your computer and downloaded at [www.alpha.ca/downloads](http://www.alpha.ca/downloads).

### 7.1.1 Procedure

1. Switch off the Alpha Micro Secure
2. Connect the RS-232 cable if it is not already connected.
3. While pressing and holding the **SELECT** button, switch on the battery circuit breaker. The LCD panel shows **"Alpha XP ISP"**.



4. Start **uBug12**.
5. Type (all lower case) **con**(1 space)**1**(or the number of the computer's comm port you are using) and press **ENTER**. The screen shows "connected" when the connection is established.

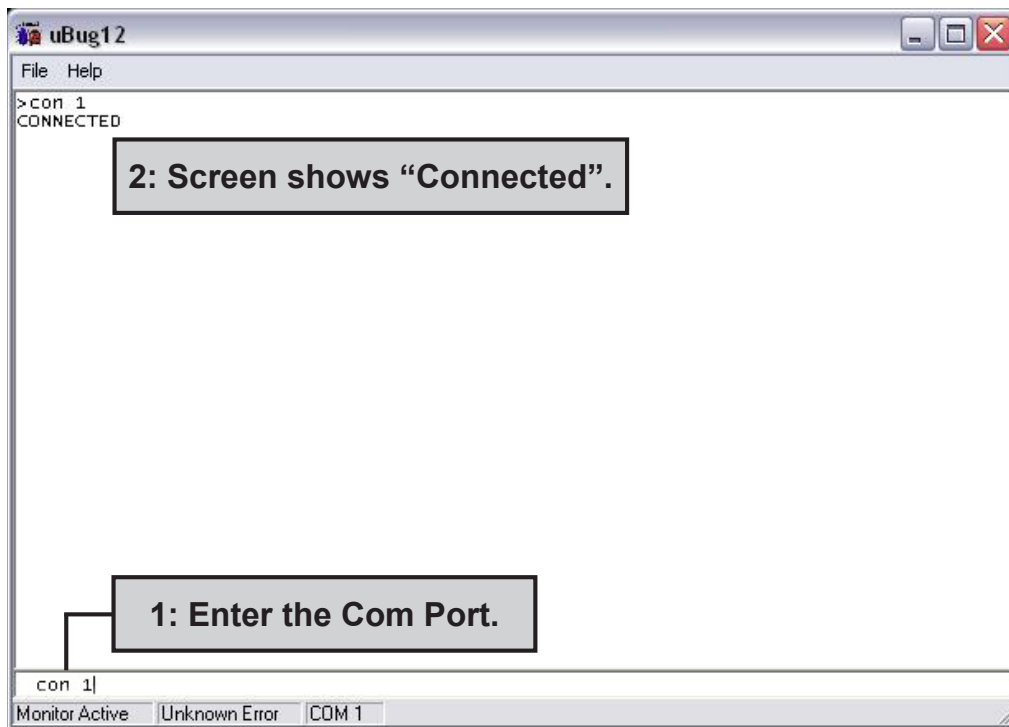

6. In the **uBug12** screen, type (all lower case) **fbulk** and press **ENTER**. The erase pop-up appears. It disappears when the Alpha Micro Secure's memory is erased. If an error message appears, send the **fbulk** command again.

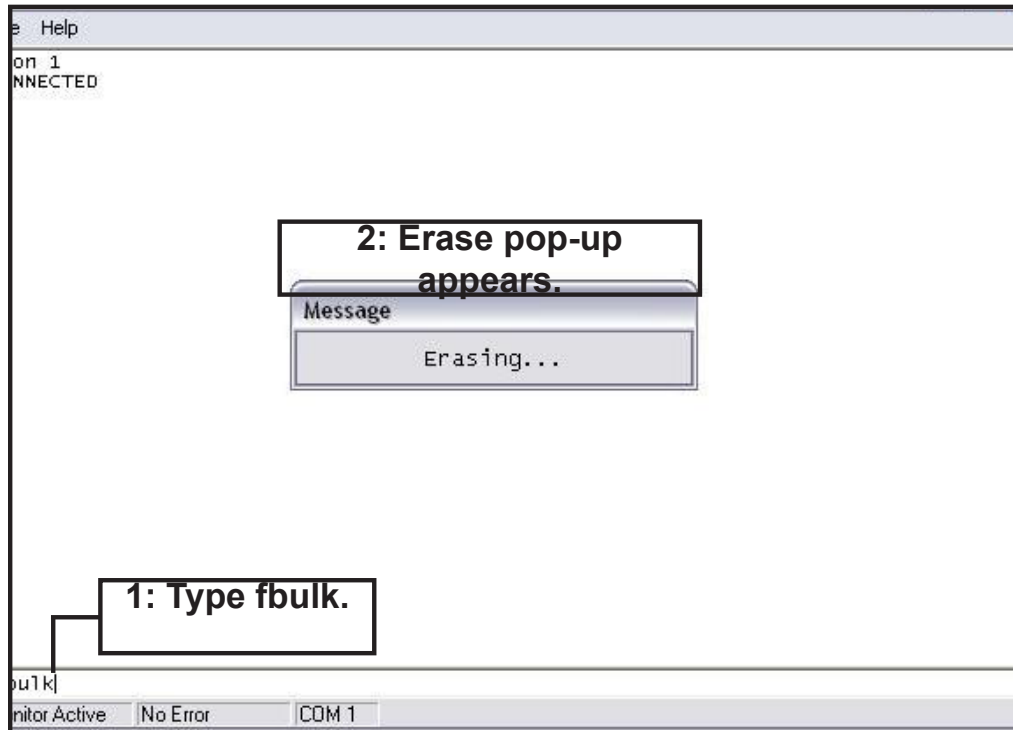

7. In the **uBug12** screen, type (all lower case) **load**(1 space);**b** and press **ENTER**. A pop-up appears asking you to locate the new firmware. Look for a "**sx record**" (\*.sx). Select this new firmware. The **load** pop-up appears.

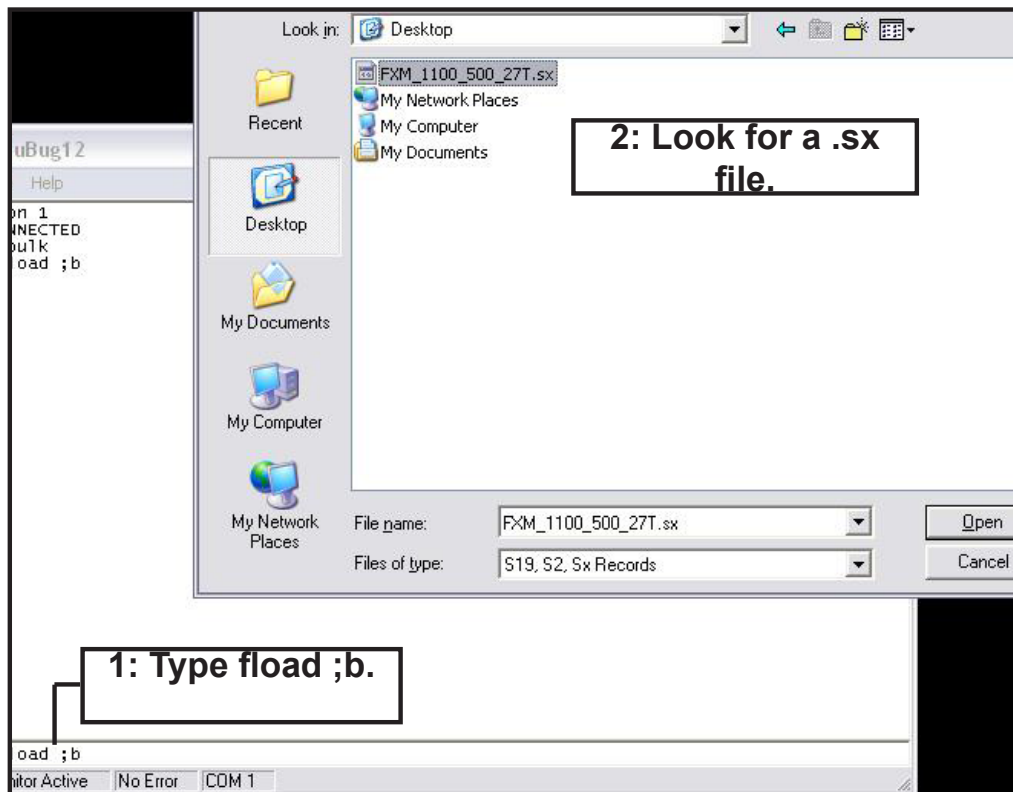

8. When the software has finished loading into the Alpha Micro Secure the pop-up shows “**Loaded OK in (xx) seconds.**” If an error message appears, switch off the Alpha Micro Secure and start over again. It should not take more than one or two restarts to load the software. If problem persists, contact Alpha technical support.

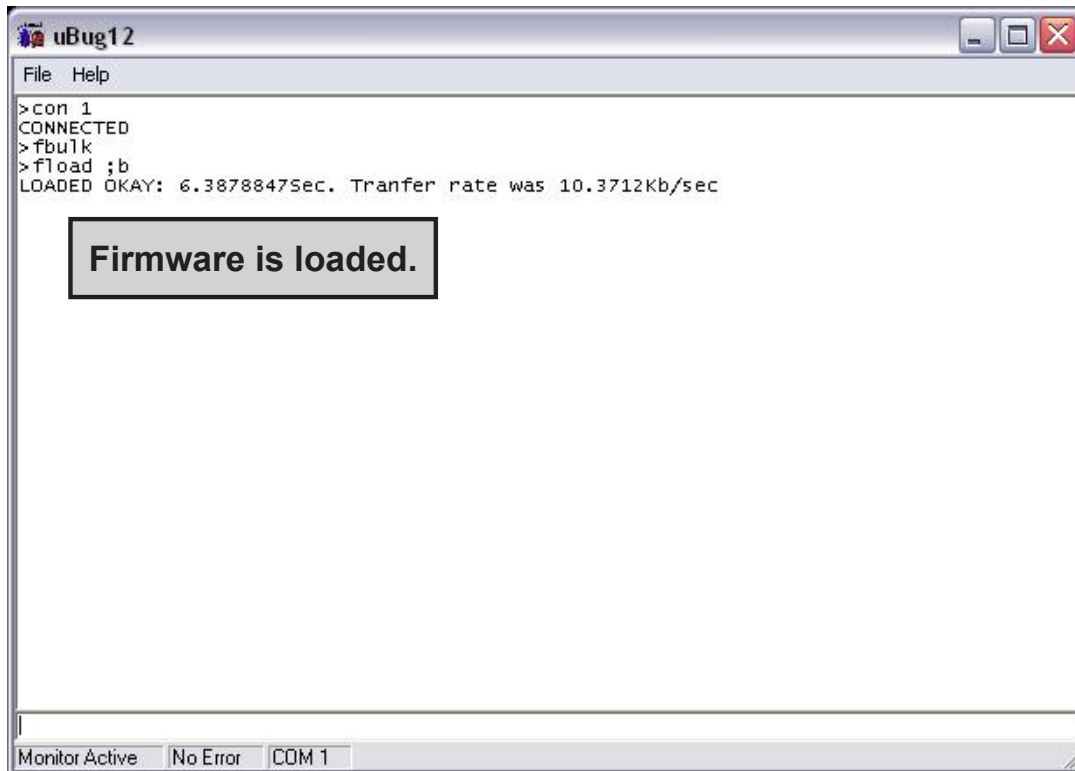

9. Type (all lower case) **exit** and press **ENTER**. The **uBug12** screen disappears.
10. Switch of the battery breaker.
11. To check if the installation was successful, switch on the battery breaker. The LCD's logo screen should appear as follows. If it shows “**Alpha XP ISP**” as shown in Step 3, try installing the firmware again.

<b>Alpha Micro300</b>	<b>120/60/N LINE</b>
---------------------------	--------------------------

## 7.2 Testing and Replacing the Batteries

### 7.2.1 Battery life

Batteries lose their ability to store power as they age. Regularly test the batteries to ensure that they can continue providing reliable service. Battery life is reduced by three major factors:

- Temperature – higher ambient temperatures, especially above 25°C, will reduce battery life. For example, an average operating temperature of 27°C will likely reduce the life of the battery by 25%. Ensure that the Alpha Micro Secure and batteries are situated in a well ventilated area with adequate temperature control. A cool environment is preferable.
- Number of discharge cycles – the more frequent the batteries are discharged, the shorter the battery life. Frequent power outages imply the need for more frequent battery replacement.
- Depth of discharge – the longer the batteries are required to provide back up power, the shorter the battery life. Frequent full discharging and the associated recharging of the batteries reduces the life. Shut down the electrical load or return to primary power as soon as possible to extend the battery life.

### 7.2.2 Battery Run Time

The chart below shows typical run times (time to full discharge) for the standard batteries supplied with this unit. These runtimes are for batteries in new and good condition. The run time performance will deteriorate over time in a progressively decreasing curve.

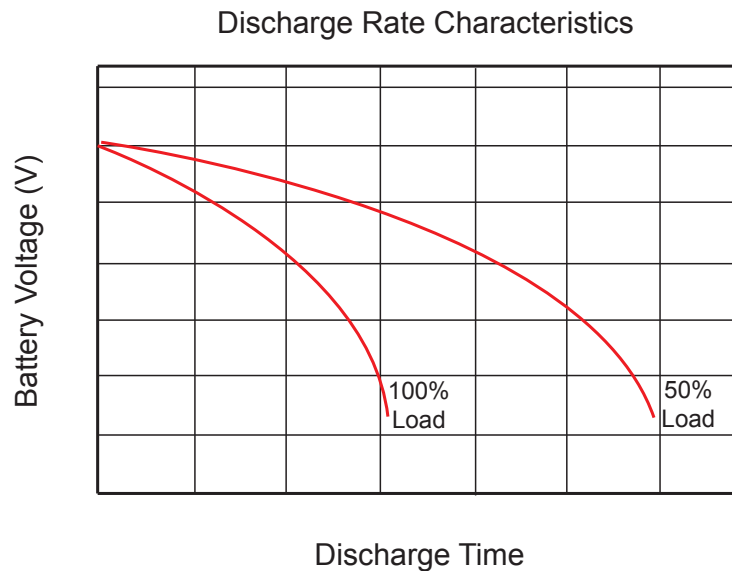

Figure 52 — Typical Discharge Characteristics for Lead Acid Batteries

### 7.2.3 Battery Maintenance

The batteries supplied with this unit are sealed and maintenance free. Regularly ensure that all connectors are tight and free of corrosion. The presence of corrosion, swelling of the battery case, or distortion in the shape of the case suggests that the batteries need to be replaced.

### 7.2.4 Battery Conductance Test (Optional)

1. Place the conductance meter probes across Battery #1.
2. Record the voltage and Siemens values in a log book.
3. Repeat for batteries #2, #3 and #4.

A new AlphaCell 180GXL battery has a conductance reference value of 1100 Siemens at 25°C. When this value drops to 550 Siemens or 50% of the new battery reference value, the battery capacity is suspect of being below 80% and should be evaluated further. When the temperature of the batteries is not between 20°C and 30°C, use the following temperature compensation values.

<b>Table N — Battery Temperature Compensation Values</b>		
<b>Battery Temperature</b>	<b>Reference Value New 180GXL</b>	<b>Suspect Value</b>
35°C or higher	1183	592
30°C	1140	570
25°C	1100	550
20°C	1063	532
15°C	1028	514
10°C	995	498
5°C	965	483
0°C or colder	936	468

### 7.2.5 Replacing the Batteries

Replace the batteries according to the results of the self test or the presence of terminal corrosion, swelling of the battery case, or distortion in the shape of the case. New batteries will normally provide longer run times than older ones. Larger capacity batteries may be available. Contact Alpha Technical Support (1 888 462 7487) to order replacement batteries or to obtain assistance. On-site service may be available in your area.

#### Tools and Materials Required

- AC/DC voltmeter or multimeter.
- Labels or masking tape and marker.
- Torque wrench.
- Slot head screwdriver to fit the terminal blocks.
- High strength, flame-proof tape such as duct tape.
- Battery terminal corrosion inhibitor (such as NOCO Company's NCP-2 or Sanchem Inc.'s No-Ox ID Grease "A").





## WARNING!

Read and understand the battery safety instructions in “Product Safety Information”.



## CAUTION!

**Make sure all the replacement batteries are of the same type and rating. Failure to do so could result in improper charging and damage to the batteries.**

The Alpha Micro Secure cannot provide backup battery power while the batteries are being replaced. If the line becomes unqualified while the batteries are being replaced, the Alpha Micro Secure shuts down and no power is provided to the load.

### Procedure

1. The Alpha Micro Secure must be in the Line state. If it isn't, wait until the line is qualified before proceeding.
2. Switch the Alpha Micro Secure into the Bypass State by doing one of the following:
  - a. From the Logo Screen, press the **SELECT** button once, the LCD shows **CONTROL**.  
Press the **SELECT** button once, the LCD shows **INVERTER**.  
Press the **SCROLL** button once until the LCD shows **INV BYPASS**.  
Press the **SELECT** button once, **OFF** is flashing.  
Press the **SCROLL** button once, **ON** is flashing.  
Press the **SELECT** button once, **ON** is solid.
  - b. From the Alpha UPS Monitor main screen, go to the **UPS Maintenance > Unit Configuration** screen.  
Switch on the **Bypass Mode** by clicking the **ON** button and then the **Update Configuration** button. The Alpha Micro Secure responds by displaying a “Bypass State” alarm. This is normal and does not indicate a problem. It will clear itself when the Bypass state is subsequently disabled.
3. Switch off the battery circuit breaker.
4. Replace the batteries.
5. Switch on the battery circuit breaker.
6. Switch the Alpha Micro Secure out of the Bypass state by switching the **Bypass Mode** OFF.

## 7.3 Preventative Maintenance

Perform preventative maintenance on the Alpha Micro Secure module every 6 to 12 months. For mission critical applications such as backup traffic intersections, more frequent maintenance should be done. Proper implementation of the following procedure will insure that your system continues to provide reliable backup power in the event of a utility power failure.

### 7.3.1 Tools and Materials Required

- Wrench set.
- Labels and marker to number batteries.
- Conductance meter for optional conductance test.

### 7.3.2 Procedure

1. Inspect the Alpha Micro Secure and wiring for any physical damage. Repair or replace as required.
2. Verify that all connections are securely fastened. Tighten if necessary.
3. Inspect the batteries for cracks or swelling. Replace all four batteries if any of the batteries are cracked or swollen. Replace only a faulty battery if an Alphaguard battery balancer is installed.
4. Inspect the battery terminals for corrosions. Clean and apply a corrosion prevention compound such as NOCO Company NCP-2 or Sanchem Inc. NO-OX-ID if required.
5. Re-tighten the battery terminal bolts on Insert Terminal batteries. Re-torque the battery terminal bolts on Flag Terminal batteries to the manufacturers specifications on if required.
6. Label the batteries #1, #2, #3 and #4. The battery negative cable from the Alpha Micro Secure is connected to Battery #1, and the battery positive cable from the Alpha Micro Secure is connected to Battery #4.
7. Verify that the battery temperature probe is securely taped to the side of either battery #2 or #3.

### 7.3.3 Operational Test

1. Activate the Alpha Micro Secure self-test function.
2. After passing the self-test, disconnect the AC input to the Alpha Micro Secure to trigger the unit into the backup (Inverter) mode.
3. Let the Alpha Micro Secure operate in the backup mode for approximately 10 minutes.
4. Measure the individual battery voltages while the Alpha Micro Secure is operating in the backup mode. There should be no more than 0.6 volts difference between the highest battery voltage and the lowest battery voltage.



### CAUTION!

**A battery that measures 2 V lower than the other three batteries in the string probably has a shorted cell. Replace all four batteries.**

**Three batteries in the string measuring the same voltage and one battery measuring several volts higher indicates an open cell in the battery with the higher reading. Replace all four batteries.**

5. Verify that there is no Low Battery Alarm.
6. Reconnect the AC input.

## 8. Troubleshooting

---

**Table O — Troubleshooting Guide**

Symptom	Action
<b>No output power</b>	Is utility power connected? Is the battery fuse installed? Are the batteries discharged? Is the input circuit breaker open?
<b>No battery backup power</b>	Is the battery fuse connected or is it blown? Are the batteries discharged?
<b>No power to load</b>	Is the UPS's output properly connected to the load? Is the battery fuse connected or is it blown and is the utility power connected to UPS's input connector?

If you have the RS-232 computer communication enabled, then you can perform additional troubleshooting. See "Communicating with the RS-232 interface", "Using the Main Menu", and "Communicating with the Alpha UPS Monitor".

## 9. Specifications

**Table P — Mechanical Specifications**

Parameter	Value
<b>Dimensions H x W x D mm (in)</b>	Std: 15 (381) x 12 (305) x 6 (153)
<b>Weight without batteries kg (lb)</b>	50 (22.7) with 4 batteries 25 (11.3) without batteries
<b>Mounting</b>	Wall or pole (with optional bracket Alpha Kit# 740-751-21)
<b>Humidity</b>	Operating: Non-condensing up to 95%. Storage: Up to 95%.
<b>Temperature, °C Operating Storage</b>	–40 to 122 (–40 to 50) –40 to 167 (–40 to 75)
<b>Altitude, m (ft) Operating Storage</b>	Up to 3700 (12,000). Up to 4600 (15,000).
<b>AC input and output connectors</b>	3-position terminal block (maximum 10 AWG)
<b>Dry contact ATC connectors</b>	Terminal block, mating plug JITE p/n PTB750B-03-1-03-3 or equivalent (max 16 AWG).
<b>RS-232 connector</b>	Surveillance version: DE-9, female Cable version: None
<b>Ethernet connector</b>	Optional, factory installed RJ-45.
<b>Dry contacts</b>	Surveillance version: Two programmable dry, single pole double-throw relays. Contacts are rated at 120VAC, 1A. The factory default settings are: C1: On battery, C2: Low battery Cable version: None
<b>Displays</b>	Surveillance version: Two LEDs (1 red and 1 green) via communication board. Cable version: Two LEDs (1 red and 1 green) mounted on the enclosure visible from the outside.

**Table Q — Electrical Specifications**

Parameter	Value
<b>Input</b>	
<b>Voltage (nominal), VAC</b>	120 or 230 (optional 220).
<b>Frequency, Hz, ±5%</b>	60/50 (auto-frequency).
<b>Current, A</b>	2.0 @ 120 VAC 1.0 @ 220/230 VAC
<b>Output</b>	
<b>Voltage (nominal), VAC</b>	Surveillance version: 120 or 230 ± 10% 24, -5% to +20% Cable version: 63 -10/+13%
<b>Frequency, Hz, ±5%</b>	60/50 (auto-frequency).
<b>Current, A</b>	4.20 @ 24 VAC 1.59 @ 63 VAC 0.83 @ 120 VAC 0.43 @ 230 VAC
<b>Power, W/VA</b>	100 total including auxiliary output
<b>Waveform</b>	Sine wave
<b>Load Crest Factor</b>	3:1 (load dependent)
<b>Output Voltage Distortion</b>	< 3% THD (resistive load)
<b>Efficiency Normal Mode Backup (Inverter) Mode</b>	> 85% > 75%
<b>Transfer Time, ms AVR to Backup Backup to AVR</b>	5 (Typical) 3 (Typical)
<b>Line Qualification Time, s</b>	3
<b>Battery String Voltage</b>	24
<b>Battery Charger Current (Factory default, A)</b>	3
<b>Battery Charger Temperature Compensation</b>	-5 mV / °C / Cell (factory default), user adjustable to -2.5, -4, -5 and -6 mV / °C / Cell via RS-232 connection.
<b>Battery size</b>	Standard: 4 x 18 to 2 x 50 Ahr
<b>Other</b>	
<b>Battery Fuse)</b>	T4A 250 V for 24 V battery string voltage

<b>Table R — Regulatory</b>	
<b>Parameter</b>	<b>Value</b>
<b>Electrical Safety</b>	UL 1778, CSA 107.1, EN 50091-1-2, EN60950.
<b>Emission</b>	FCC Part 15, Subpart B, Class A, CISPR22, EN55022 Level A.
<b>Marks</b>	cCSA <sub>US</sub> , CE (230 VAC versions only).
<b>Packaging</b>	Designed to meet requirements for ISTA program.

## **Radio Frequencies**

The Alpha Micro Secure generates, uses and radiates radio frequencies if not installed and tested in accordance with the instructions in this manual. It has been tested and found to comply with the limits established for a Class A computing device pursuant to part 15 of FCC rules and CISPR 22 when it is operated alone. It also complies with the radio interference regulations of DOC which are designed to provide reasonable protection against such interference to radio to TV reception, which is determined by switching it on and off, relocate the equipment or use an electrical circuit other than the one used by the Alpha Micro Secure.

# 10. Peukert Number and Battery Capacity

---

## 10.1 Introduction

The Alpha Micro Secure series UPS units run on batteries when the AC utility power fails. In this mode, the user may want to estimate the remaining time that UPS batteries can supply power to the loads.

The battery run time remaining is calculated based on the Peukert equation. Two critical parameters are required for the equation:

- Peukert number.
- Peukert capacity.

The Peukert number and Peukert capacity depend on the battery characteristics. This document describes the procedures to determine the Peukert number, and Peukert capacity for the selected battery.

Once the Peukert's number and capacity are determined, enter these values in the GUI or web interface. The Alpha Micro Secure will report the remaining battery run time.

The Peukert's equation and the remaining battery run time are estimates only. The actual run time may vary based on various parameters like the age and status of the batteries etc.

## 10.2 Determining the Peukert's Number and Peukert's Capacity

1. Obtain the data sheet of the selected battery.
2. Calculate the nominal load current for the application.

Example: If the load is 150 W and the battery string is 24 VDC, the load current is calculated as  $150 \text{ W} / 24 \text{ V} = 6.25 \text{ A}$ .

3. Find the current discharge ratings table in the data sheet. From the table, pick two current discharge values ( $I_1$  and  $I_2$ ) that are closest to the calculated load current and look up the two discharge hours ( $R_1$  and  $R_2$ ).
4. Use the following formula to calculate Peukert's number and capacity:

$$\text{Peukert's number} = n = \frac{\text{Log}(R_2/R_1)}{(\text{Log}(I_1) - \text{Log}(I_2))} \dots\dots\dots (1)$$

$$\text{Peukert's capacity} = (I_1)^n \times R_1 \text{ per battery} \dots\dots\dots (2)$$

## 10.3 Determining Peukert's Capacity for Series Parallel Combinations

1. For batteries connected in series, the Peukert's capacity for the battery bank is given by the equation:

$$\text{Peukert's capacity}_{\text{Battery bank}} = \text{Peukert's capacity}_{\text{per battery}} \text{ Ah} \\ \text{(as calculated in equation (2))}$$

2. For batteries connected in parallel, the Peukert's capacity for the battery bank is given by the equation:

$$\text{Peukert's capacity}_{\text{Battery bank}} = \text{Peukert's capacity}_{\text{per battery}} \times N \text{ Ah} \\ \text{(where N = number of batteries in parallel)}$$

## 10.4 Example

The following example shows how to calculate Peukert's number and capacity from a configured battery string. Consider four Alpha 180GXL batteries connected and configured as shown in the figure below. Two of the four batteries are connected in series, and the two series strings are connected in parallel to the 24 V DC output.

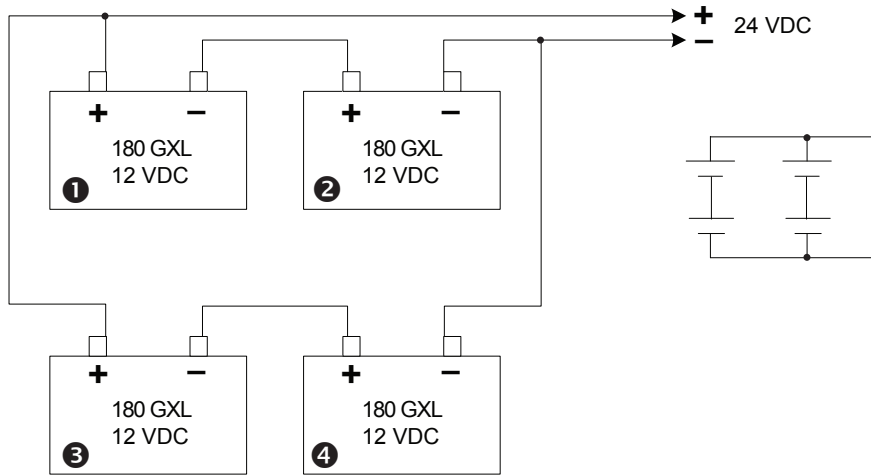

Figure 53 — Battery string example

The Peukert's number and capacity for the above configuration can be determined as follows:

1. Obtain the data sheet of the selected battery. See table below.
2. Find the current discharge ratings table in the data sheet. From the table, pick two current discharge values ( $I_1$  and  $I_2$ ) that are closest to the calculated load current value. Look up the two discharge hours ( $R_1$  and  $R_2$ ).

Current Discharge Ratings Table in Amps (end Voltage 1.75VPC)													
Hours	1	2	3	4	6	8	10	12	20	24	48	72	100
215 Gold	67.8	40.5	29.1	22.9	16.1	12.6	10.2	8.7	5.46	4.61	Call*	Call*	Call*
210 GXL	66.3	39.6	28.5	22.4	15.8	12.3	10.0	8.54	5.34	4.51	Call*	Call*	Call*
190 Gold	64.5	37.1	26.6	20.8	14.6	11.4	9.4	7.9	4.96	4.2	2.2	1.5	1.08
180 GXL	61.2	35.2	25.2	19.7	13.9	10.8	8.9	7.5	4.7	4.0	2.1	1.4	1.03
85 GXL HP	33.2	18.8	13.5	10.4	7.34	5.70	4.88	3.97	2.50	2.12	1.11	0.76	0.56

\* Call Alpha for current discharge ratings.

3. From the table,  $I_1 = 13.9\text{A}$ ,  $I_2 = 10.8\text{A}$ ,  $R_1 = 6\text{ hrs}$ ,  $R_2 = 8\text{ hrs}$ .

From Equation (1) earlier:

$$\text{Peukert's number} = n = \frac{\text{Log}(R_2/R_1)}{(\text{Log}(I_1) - \text{Log}(I_2))}$$

$$n = \frac{\text{Log}(8/6)}{\text{Log}(13.9) - \text{Log}(10.8)} = 1.14$$

From Equation (2) earlier

$$\begin{aligned} \text{Peukert's capacity} &= (I_1)^n \times R_1 \text{ per battery} \\ &= (13.9)^{1.14} \times 6 \\ &= 120.55 \text{ Ah per battery} \dots\dots\dots (3) \end{aligned}$$

4. The Peukert's capacity for the series combination (Batteries #1 and #2) is 120.55 Ah.
5. The Peukert's capacity for the parallel combination (Batteries #1, #2 and #3, #4) is  $2 \times 120.55 \text{ Ah} = 241.10 \text{ Ah}$ .



## 10.5 Using the Spreadsheet

Download the spreadsheet "Peukert's Parameters Calculator.xls" from [www.alpha.ca](http://www.alpha.ca) website.



**To determine Peukert's Number and Peukert's Capacity**

This spreadsheet assists in determining the Peukert's parameters for a battery string and load. This data will be used by the FXM firmware 1.07 to estimate the battery run time remaining in back up mode (Invert mode)

Enter Battery String Voltage	24	VDC
Enter nominal load on inverter	275	Watts
Calculated nominal current	11.46	ADC

From the Current discharge table enter the 2 current discharge values ( $I_1$  and  $I_2$ ) closest to the calculated load current value and look up the 2 discharge hours ( $R_1$  and  $R_2$ ).

Discharge Current ( $I_1$ )	13.9	A
Rating 1 ( $R_1$ )	6	Hrs
Discharge Current ( $I_2$ )	10.8	A
Rating 2 ( $R_2$ )	8	Hrs

Peukert's Number = n	1.140
----------------------	-------

Peukert's Capacity per Battery =	120.570
----------------------------------	---------

Enter Number of Battery strings in Parallel	2
---	---

Peukert's Capacity for the Battery Bank =	241.140
---	---------

Enter the Battery voltage and nominal load

From the data sheet of the batteries enter the 2 closest currents and discharge hours

Enter the number of parallel strings

# 11. Warranty

---

Alpha Technologies Ltd. warrants all equipment manufactured by it to be free from defects in parts and labor, for a period of two years from the date of shipment from the factory. The warranty provides for repairing, replacing or issuing credit (at Alpha's discretion) for any equipment manufactured by it and returned by the customer to the factory or other authorized location during the warranty period. There are limitations to this warranty coverage. The warranty does not provide to the customer or other parties any remedies other than the above. It does not provide coverage for any loss of profits, loss of use, costs for removal or installation of defective equipment, damages or consequential damages based upon equipment failure during or after the warranty period. No other obligations are expressed or implied. Warranty also does not cover damage or equipment failure due to cause(s) external to the unit including, but not limited to, environmental conditions, water damage, power surges or any other external influence.

The customer is responsible for all shipping and handling charges. Where products are covered under warranty Alpha will pay the cost of shipping the repaired or replacement unit back to the customer.

## 11.1 Battery Warranty

Note that battery warranty terms and conditions vary by battery and by intended use. The most common battery warranty provided by Alpha is a two year full replacement warranty with a pro-rated warranty for the following three years. Pro rated warranty provides a credit applicable toward the purchase of new batteries from Alpha. The credit is calculated as the purchase price multiplied by the percentage of the battery life that was not available (in months). Battery warranty coverage is lost where the battery charge is not maintained for 6 months. Contact your Alpha sales representative or the Technical Support team at the above number to understand your entitlements under Battery Warranty.

## 12. Emergency Shutdown Procedure

---

The Alpha Micro Secure UPS contains more than one live circuit. In an emergency, line power may be disconnected at the UPS's input, but AC power can still be present at the output.

1. Switch OFF the input circuit breaker.
2. Remove the internal battery fuse.
3. Disconnect the AC input power.
4. Disconnect the internal battery string.

### Complete the following for your records:

Serial # \_\_\_\_\_

Options \_\_\_\_\_

Purchase Date \_\_\_\_\_

### This unit was purchased from:

Dealer \_\_\_\_\_

City \_\_\_\_\_

State/Province \_\_\_\_\_

Zip/Postal Code \_\_\_\_\_

Country \_\_\_\_\_

Telephone # \_\_\_\_\_

Fax # \_\_\_\_\_

E Mail Address \_\_\_\_\_

**Alpha Technologies Ltd.**

7700 Riverfront Gate  
Burnaby, BC V5J 5M4  
Canada  
Tel: +1 604 436 5900  
Fax: +1 604 436 1233  
Toll Free: +1 800 667 8743

**Alpha Energy**

1628 W Williams Drive  
Phoenix, AZ 85027  
United States  
Tel: +1 602 997 1007  
Fax: +1 623 249 7833

**Alpha Technologies Europe Ltd.**

Twyford House Thorley  
Bishop's Stortford  
Hertfordshire, CM22 7PA  
United Kingdom  
Tel: +44 1279 501110  
Fax: +44 1279 659870

**Alpha Technologies**

Unit 504, 5/F,  
Fourseas Building  
No 208-212 Nathan Road  
Kowloon, Hong Kong  
Tel: +852 2736 8663  
Fax: +852 2199 7988

**Alpha Technologies Inc.**

3767 Alpha Way  
Bellingham, WA 98226  
United States  
Tel: +1 360 647 2360  
Fax: +1 360 671 4936

**Alpha Technologies GmbH**

Hansastraße 8  
D-91126  
Schwabach, Germany  
Tel: +49 9122 79889 0  
Fax: +49 9122 79889 21

**Alphatec Ltd.**

339 St. Andrews St.  
Suite 101 Andrea Chambers  
P.O. Box 56468  
3307 Limassol, Cyprus  
Tel: +357 25 375 675  
Fax: +357 25 359 595

**Argus Brasil Serviços e Comércio Ltda.**

Av. Bernardino de Campos, 332 - loja 2  
Campo Grande - Santos - SP  
CEP: 11065-000 - Brazil  
Tel: +55 13 3345 0881  
Cell.: +55 13 7806 1438

**Alpha Industrial Power Inc.**

1075 Satellite Blvd NW,  
Suite 400  
Suwanee, GA 30024  
United States  
Tel: +1 678 475 3995  
Fax: +1 678 584 9259

**Technologies Argus First de Mexico**

Anatole France Num. 17  
Colonia Polanco  
11560, México D.F.  
Tel: +52 55 5280 6990

**Alpha TEK ooo**

Khokhlovskiy Pereulok 16  
Stroenie 1, Office 403  
Moscow, 109028  
Russia  
Tel: +7 495 916 1854  
Fax: +7 495 916 1349

**Alphatec Baltic**

S. Konarskio Street 49-201  
Vilnius, LT-03123  
Lithuania  
Tel: +370 5 210 5291  
Fax: +370 5 210 5292

Visit us at [www.alpha.ca](http://www.alpha.ca)

*Power*